



**WALKING HORSE OWNERS ASSOCIATION
FLATSHOD TENNESSEE WALKING HORSES**

**OFFICIAL
VERSATILITY
RULEBOOK**

**Walking Horse Owners' Association
P.O. Box 4007
Murfreesboro, TN 37129
615-494-8822 Phone
615-494-8825 Fax
Email: joinwhoa@aol.com
www.walkinghorseowners.com**

Effective March 1 2024

©2015 Walking Horse Owners' Association, Inc. Any use of the Walking Horse Owners' Association Rulebook, in whole or in part, is strictly prohibited unless used at Walking Horse Owners' Association affiliated or sponsored events.

Table of Contents

Statement of Policy	4
Equipment and Attire For Versatility Classes	5
Dressage	17
Driving Division.....	13
Pleasure Driving	13
Heritage Driving	15
Concours D'Elegance	15
Reinsmanship.....	15
Combination – Ride and Drive	16
Obstacle Driving	16
Gambler's Choice	22
Equitation Division	26
Walking Seat Equitation	26
Stock Seat Equitation.....	31
Game Classes	42
Water Glass.....	42
Egg and Spoon	42
Ride-A-Buck.....	42
Musical Sacks	42
Musical Chairs	43
Back To Back.....	43
Baby Bottle Race	43
Halter Division	43
Model.....	44
In-Hand	44
Reining Division	46
Showmanship Division	62
Timed Events/Contests Classes.....	69
Cloverleaf Barrels	70
Quadrangle Barrels	71
Straight Line Barrels.....	72
Texas T Barrels	73
Pole Bending.....	74
Keyhole Race	75
Stake Race.....	76
One Barrel Speed	77
Arena Flag Race.....	78

Handy Horse	79
Catalog Race	80
Timed Driving Events	80
Driving Barrel Race	81
Driving Pole Bending	81
Trail Obstacle Division	82
In-Hand Trail	86
TWH Over Fences	91
TWH Hunter Hack	96
Green Hunter	96
TWH, Open Jumping	96
Western Riding Division	98
Working Plantation Horse Competition	109
Items Needed For Classes	116

Statement of Policy

Knowledge of the rules of any sport is required of each participant and exhibitors at horse shows must adhere to this responsibility. Exhibitors must be fully aware of all rules and class specifications in the division or divisions in which he or she participates.

It is obvious that, no matter how complete rules may be, they can never cover all possible situations that may arise. If a situation cannot be resolved by interpreting the rules to the letter, the resolution will follow as nearly as possible the spirit of the rule.

Eligibility

1. Breeds of horses that are eligible to show in any Versatility class in this Rulebook are Tennessee Walking Horse, Racking, Spotted Saddle or other gaited breeds but do not have to be registered.
2. All classes are open to any rider unless class is specified as amateur or youth.
3. Children of trainers may show horses that are owned by others.

Judging

1. Judges are required to complete scoresheets following classes which entries are evaluated by individual work and/or pattern work (i.e. Trail Obstacle, Basic Reining, Western Riding, Showmanship).

EQUIPMENT AND ATTIRE FOR VERSATILITY CLASSES

CLASS	REQUIRED	SUGGESTED	ALLOWED	PROHIBITED
Contest Classes/Timed Events (includes barrel racing, pole bending, keyhole, stake race, etc.)	Western tack & attire (long sleeve collared shirt, boots with heel & cowboy hat or helmet; Western saddle & bridle, without cavesson. Hat must remain on rider's person until horse & rider leave the ring.	Approved helmet or hard hat.	Martingales, tie downs, protective leg coverings (boots, wraps, etc.), riding helmets, spurs. Cavesson Quick change bridle and reins	Whips, bats, or crops of any kind. Gag bits without shanks, bits with shanks over 9 1/2 inches
Dressage	English saddle & bridle with regular cavesson, dropped or flash noseband. Plain snaffle bit without shanks. Bits must be smooth & solid and must be made entirely of the same metal. English attire.		Breastplate, whip no longer than 4', blunt spurs, protective head gear for rider.	Martingales, bit guards twisted wire or roller bits, any shanked bit, boots or bandages.
Western Dressage	Western Tack & Attire- Suitable western hat. Western boots Long-sleeved shirt with any type of collar, pants, a one-piece long sleeved equitation suit with collar.	Optional apparel: Necktie, kerchief, bolo tie or pin, vest, jacket, coat and/or sweater. spurs, or chaps,	Protective headgear may be worn without penalty.	Tall English boots, clearly visible on the outside of pant Spurs with sharp tines Plain English half chaps
Driving Events (includes pleasure driving, obstacle driving, etc.	Pleasure harness with snaffle bit. For ladies: conservative dress, blouse & shirt, shirt & jods with apron, saddle suit or day coat with jods. For men: business suit, saddle suit, Sport coat & slacks.	Gloves, whip of length appropriate to length of vehicle & horse	Separate overcheck bit, apron, hat. Fine harness and stirrup type carts	Shanked bits of any kind.
Game Classes (includes classes such as water glass, ride a buck, egg & spoon, etc.)	Tack & attire may be either English (saddle suit, Jodphur boots English type saddle and bridle with cavesson) or Western ((long sleeve collared shirt, Western type pants, boots with heel & cowboy hat or helmet; Western saddle & bridle, but not a combination of both. Riding coats may be omitted		Cavesson. Quick change bridle and reins.	Gag bits without shanks, shanked bits longer than 9 1/2 inches long.

CLASS	REQUIRED	SUGGESTED	ALLOWED	PROHIBITED
Reining; Western Riding	Western tack & attire, including long sleeve collared shirt, boots with heel and cowboy hat or helmet. Chaps, vests, jackets are optional. Western saddle & bridle, without cavesson.	Approved helmet or hard hat.	Protective leg coverings (boots, wraps, etc.), riding helmets, spurs.	Whips, bats or crops of any kind and cavessons .. Judge may disqualify an entry if, in the judge's opinion, the bit is severe.
Showmanship at Halter	Tack & attire may be either English (saddle suit, jodphur boots, English style hat & gloves) or Western (long sleeve collared shirt, Western style pants, Western boots, Western hat, gloves) but not a combination of both. Halter .		Exhibitors attired in Western may wear a vest or jacket and/or chaps.	Whips, braids with Western tack & attire.
TWH over Fences	Hunt seat tack & attire, including forward seat or all-purpose saddle, English bridle with cavesson, and snaffle, Kimberwick or Pelham bit. Hard hat and boots.		Whip not to exceed 4 ft., protective leg coverings (non-weighted boots, wraps, etc.), martingales. spurs	Cutback saddles, any bit other than those in the required section. Whips not over 4ft "with crop"
Trail	Tack & attire may be English (saddle suit, or day coat, jodphur boots) or Western (long sleeve collared shirt, Western style pants & boots, Western hat) but not a combination of both. English style tack includes English saddle & bridle with cavesson. Western tack includes Western saddle & bridle without cavesson.		Protective leg coverings (non-weighted boots, wraps, etc.) Cavesson	Whips. Cavesson with Western tack

DRESSAGE

The object of dressage is the harmonious development of the physical and mental ability of the horse and rider. The result is a horse that is more calm, supple and flexible, but also confident and attentive, thus developing perfect unison between horse and rider.

For tack and attire, see equipment chart

Event

Dressage is trained and shown in specific levels which build on each other and which reflect the development of the skills and abilities of both horse and rider. The tests ridden in shows are used to measure the correctness of the horse's (and rider's) schooling. There are 4 levels (Introductory Level through Second Level as well as Free-style). Each level has a specified purpose, stated on the test form. In addition, each movement in the test has a description of what the movement is and what is needed to perform it correctly. Scoring for the tests is based on both individual movements and collective marks. In addition, certain movements have coefficients that make them more important.

Basis of Collective Marks

Gaits – Freedom and regularity (goes with list below)

Impulsion – Horse's desire to move forward, elasticity of steps, roundness

Submission – Horse's attention and confidence, lightness of movement, acceptance of the bit and harmony with rider

Rider's position and seat – Correctness and effect of rider's aids

Scoring

10 Excellent

9 Very Good

8 Good

7 Fair

6 Satisfactory

5 Sufficient

4 Insufficient

3 Fairly bad

2 Bad

1 Very bad

0 Not performed

Basic Faults (Severely penalized; scoring of 3, 4, or lower)

- Impure gaits
- Incorrect basics
- Incorrect head position
- Insufficient impulsion

- Disobedience, resistance or evasion
- Incorrect seat of rider

Main Faults (Scoring 4 or 5)

- Unsteady head position
- Poor transitions
- Insufficient or incorrect bend
- Lack of self-carriage
- Lack of straightness

Minor Faults (May score 5 or above, treated lightly unless they are recurring)

- Basic and main faults that happen only momentarily
- Shying
- Stumbling

Penalties (to be indicated by ring of the bell)

- Off course
- Fall of rider and/or horse

Penalties (not to be indicated by ring of the bell)

- Not placing reins in one hand during salute
- Use of voice and clucking to horse

Elimination

- Failure to enter arena with 45 seconds after ringing the start bell
- Lameness
- Illegal equipment
- Horse stepping outside the ring with all four feet during test
- Unauthorized assistance
- Cruelty or unsportsmanlike conduct
- Horse out of control so that exhibitors or spectators are endangered

A judge may stop a test and/or allow an exhibitor to restart a test if, in his discretion, a test has been interrupted due to unusual circumstances.

The arena is traditionally formed by a low white fence or chain. The judge and scribe sit at C. Riders enter at A. The letters along the arena fence designate where movements are to be executed; the letters also assist the rider in judging specific distances, such as the size of a circle. The three dotted circles are the three primary 20 m circles. The dashed line from C to A is the centerline.

Tests for dressage events change throughout the years. WHOA follows the rules of USEF. Updated tests may be viewed on their website.

Standard Arena

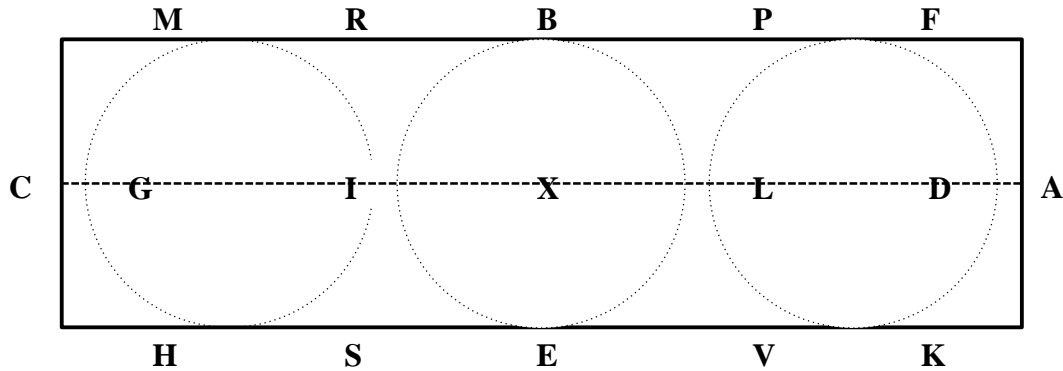

6 meters from ends of arena to first letters, 12 meters between other letters. 10 meters from D to F and D to K.

Small arena

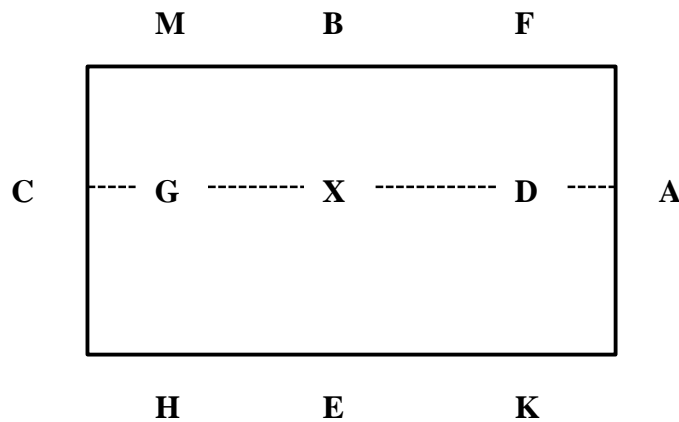

Lower level tests may be adjusted & performed in the small arena. 6 meters between end of arena and first letter, 14 meters between other letters. 10 meters from D to F and D and K.

Routine

- Test may be held in a standard dressage arena, which is 20 meters by 60 meters (about 66 feet by 198 feet)
- Test may be held in a small dressage arena, which is 20 meters by 40 meters (about 66 feet by 132 feet)
- Rider may begin schooling around the dressage arena when the rider before him has received his final salute from the judge and begins to exit the arena.

- Upon a signal from the judge (bell or whistle) the competitor has 45 seconds to enter the dressage arena.
- Dressage tests may be called by someone standing behind the letter E or B, or the test may be ridden from memory.

Freestyle Dressage

Freestyle Dressage combines the elegance and beauty of the horse with the stirring impact of music. Movements and figures are choreographed to meet the technical requirements of the particular level with music that highlights the horse/rider combination. Freestyle Dressage is entertaining and offers great audience appeal. The exhibitors are scored on a combination of technical requirements and artistic impression.

First Level Freestyle

Conditions:

Maximum time 5:00 min.

Maximum Points: 240

(120 technical, 120 artistic)

Technical requirements:

	Test
1	Walk (20 meter minimum continuous free walk
2	10 meter circle in flat walk
3	Leg yield in medium walk*
4	Lengthen stride in running walk
5	15 meter circle in canter*
6	Change of lead through flat walk *
7	Lengthen stride in canter

* Movements which must be shown on each rein.

Second Level Freestyle

Conditions:

Maximum time: 5:00 min.

Maximum points: 240

(120 technical; 120 artistic)

Technical requirements:

	Test
1	Walk (20 meter minimum continuous free walk)
2	Shoulder in at medium walk *
3	**Travers and/or renvers at medium walk*
4	Medium running walk
5	10 meter circle at canter *
6	Simple change of lead *
7	Medium canter

* Movements which must be shown on each rein.

** At least one must be shown in both directions.

Third Level Freestyle

Conditions:

Maximum time 5:00 min.

Maximum Points: 240

(120 technical, 120 artistic)

Technical requirements:

	Test
1	Walk (20 meter minimum continuous extended)
2	Shoulder in *
3	Medium walk half-pass *
4	Running walk
5	Canter half-pass *
6	Counter canter *
7	Flying change of lead *
8	Extended canter

* Movements which must be shown on each rein.

Fourth Level Freestyle

Conditions:

Maximum time 5:00 min.

Maximum Points: 240

(120 technical, 120 artistic)

Technical requirements:

	Test
1	Walk (20 meter minimum continuous collected)
2	Walk (20 meter minimum continuous extended)
3	Medium walk half-pass *
4	Running walk
5	Shoulder in *
6	Canter half-pass *
7	Extended canter
8	Flying lead changes of lead every 3 rd stride (3 changes minimum)
9	Canter half pirouette *

* Movements which must be shown on each rein

“WESTERN DRESSAGE”

Western dressage test are also revised at periodic intervals. Current test and specific rules can be found at www.westerndressageassociation.org

DRIVING DIVISION

PLEASURE DRIVING

Turnout

- Harness is traditionally black or brown leather with square patent leather blinkers, snaffle bridle with side check or overcheck, snaffle bit and running martingale. Separate overcheck bit is optional. Bridle should fit snugly to prevent catching on the vehicle. Breast collars are appropriate with lightweight vehicles.
- A whip of length appropriate to the horse and cart may be used.
- Judges have discretion to adjust rules for attire for weather conditions.
- Driving vehicle may be two or four wheeled and of suitable appearance and safety. **Fine harness and stirrup type carts are prohibited.** (Show management may limit classes to two or four wheel carts) The vehicle should be appropriate to the size, type and weight of the horse. Fine harness vehicles and stirrup type carts or sulkies are prohibited in pleasure driving. The judge must excuse a competitor with unsafe vehicle or harness.
- Only the driver is allowed in the cart. Exception: Youth driver may have one adult attendant in cart.
- Minor adjustments may be made upon permission from the judge.

Event

Horses enter the ring to the right (counter clockwise) and work both ways of the ring at flat walk and running walk. Entries reverse on the diagonal at a walk or at the direction of the ringmaster. Horses are to line up, stand quietly, and back readily. Drivers must always keep a safe distance from other vehicles, especially in passing and lining up. One neatly attired header may enter ring at lineup. Header may unfasten overcheck and wipe the horse off, but may not hold the horse. If the header holds the horse, the entry must be penalized. Performance of the horse must not be overshadowed by equipment turnout.

Horses are judged on the same general qualities as the flat-shod pleasure horse with manners and quality of pleasure gaits paramount. The following are suggestions to be used in judging: 70% on manners, performance, condition, style and way of going; 20% on fit, condition and appropriateness of harness and vehicle; 10% on conformation and neatness of driver.

Penalties

- An uncontrollable horse must be immediately dismissed with assistance if necessary.
- Illegal bits or other equipment will result in disqualification
- Assistance over the rail will result in disqualification

Diagrams of driving harness, bridles and typical pleasure cart

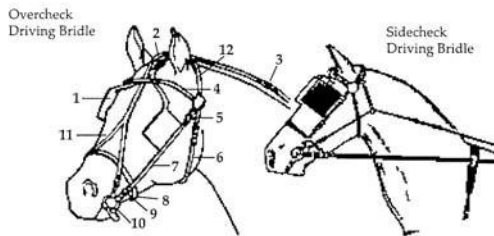
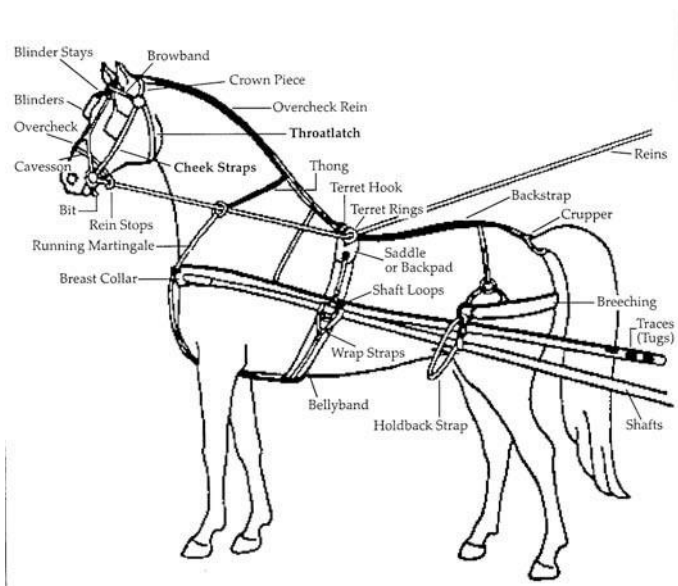

Parts of the Driving Bridle

- | | |
|-------------------------|----------------------------|
| 1. Blinder | 7. Cheek straps |
| 2. Blinder stays | 8. Noseband |
| 3. Checkrein adjustment | 9. Cheek adjustment |
| 4. Browband | 10. Half-cheek snaffle bit |
| 5. Blinder adjustment | 11. Overcheck |
| 6. Throatlatch | 12. Crown piece |

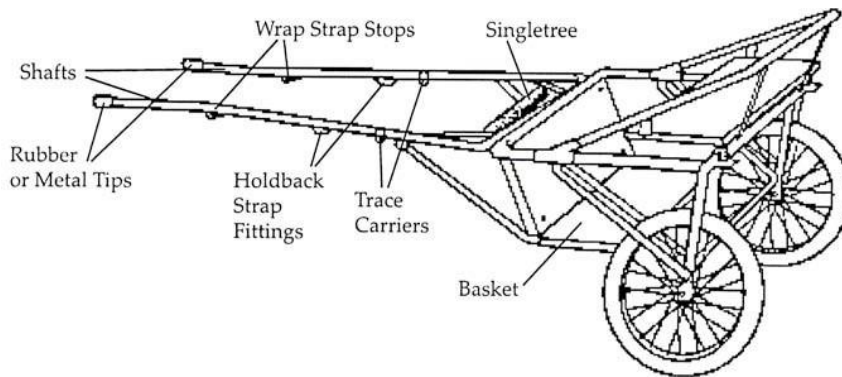

HERITAGE DRIVING

Heritage driving is judged 50% on performance of the horse, 20% on apparel of driver, 15% on the vehicle and 15% on the harness.

- Apparel must conform to the vintage of the vehicle. Hat, gloves, lap robe or apron and whip are required.
- Antique type vehicles should be safe and sound. The vehicle should be appropriate to the horse with a pleasing balance between the two.
- Harness should be clean and in good repair. Harness must fit the horse properly.

CONCOURS D'ELEGANCE

The overall picture of horse, appointments, vehicle, apparel of driver, attendants and passengers must be one of the utmost elegance. Performance will not be judged unless it detracts from the elegance of the turnout. Period costumes are prohibited unless specified by the class sheet.

PLEASURE DRIVING - REINSMANSHIP

A pleasure driving class in which entries are judged on the skill and ability of the driver.

Event

Horses are shown both ways of the ring at a flat walk and running walk. Drivers will be required to back in the line-up. Drivers chosen for a workout may be worked at the flat walk and running walk and may be asked to perform a figure eight.

Judged 75% on handling the reins and whip, posture, overall appearance and control of the driver and 25% on the condition of harness and vehicle and neatness of attire.

Requirements

- The driver's position on the seat must be secure, but not so stiff that sudden movement will cause loss of balance. Driver should sit up straight with the arms slightly extended, elbows slightly bent and close to the body, and look ahead between the ears of the horse. Reins should be held with a light hand, keeping constant contact with the horse's mouth. The feet should be just far enough apart to maintain balance - one foot slightly ahead of the other rather than spread apart.
- Hands are held close together with the bight (buckle) of the reins held by the little finger of the left hand.
- The whip is held in the right hand at the point of balance, resting on the forefinger and lightly in the palm of the hand by the lower three fingers. Whips should be held at a 45 degree angle to the horse.
- There are three options for holding the reins.
Option 1: Reins held between thumb and index (first) finger
Option 2: Reins held between index (first) finger and middle (second) finger
Option 3: Reins go under little finger OR between ring (third) and little (fourth) finger, come out between index (first) and middle (second) fingers, then between index finger and thumb and down through fist. This position offers the most control

COMBINATION – RIDE AND DRIVE

- Single horse to be shown first as a pleasure driving horse, then under saddle at a walk, running walk, and canter. A snaffle bit is required for the entire class.
- Exhibitor may have up to 2 assistants in changing horse from cart to saddle.
- Bridle must not under any circumstances be removed while a horse is hitched to a cart.
- Judged 50% on performance, manners, way of going and suitability in harness; and 50% on performance, manners, and way of going under saddle.
- Horse must be driven and ridden by the same person.

Pleasure driving and English pleasure rules and procedures will apply.

OBSTACLE DRIVING

Participation

- A horse may not be entered more than once in the same class unless one driver is an adult and one driver is a youth.
- A youth under 14 years may have an adult as a passenger but the adult may not touch the reins or assist the driver in any way. Such assistance would result in elimination.
- An adult that rides as a passenger may not afterward compete as a driver on the same course.

Turnout

Unless otherwise specified by show management, turnout is the same as pleasure driving.

Course

- Course consists of no more than 12 obstacles and a clearly marked start/finish line.
- Course diagram must be posted at least 2 hours before start of the class.
- Drivers must be allowed time to walk the course prior to start of a class and inspect each obstacle. Horses are not allowed on course before the competition.
- Obstacles will be marked by a pair of cones or markers with a ball atop each cone.
- Distance between the pair of cones is usually 6 to 8 inches wider than the widest axle. The width of each vehicle is measured at the ground from the outside edges of the wheels. The allowance is added and the cones aligned from corner to corner for the greatest distance between the corner of the base and the upright portion of the cone. The taper of the cone will provide clearance for normal vehicles. If not, the cones may be adjusted using the hub measurement plus the appropriate allowance. On markers with perpendicular sides, adjustment for the widest part of the vehicle at the highest part of the marker may be used.
- Each obstacle must be clearly numbered on a pair of red and white flags placed to the outside of the cones (Red on the right, white on the left) If possible, the number of an obstacle should be visible from the obstacle before it.
- Any obstacle that cannot be clearly marked must have a clearly drawn pattern

- explaining the correct entrance, exit and required path on the course diagram.
- The course and time allowed is usually determined by show management. As a general rule, suggested speed is 800 feet per minute. An average course consists of 6 obstacles to be completed in 4 minutes or less.

Suggested Obstacles

- Wooden bridges, no more than 4 inches from the ground.
- Serpentine of not more than 4 poles in a straight line.
- Zig-zag of up to 4 pair of markers.
- Obstacles in the shape of an “L”, “U”, box, etc. (must be at least 13 feet wide at entrance and 16 feet at turns).
- Circles marked in lime or flour.
- A pair of landscape timbers through which a single wheel must pass

Event

Timing starts and ends when competitor crosses start and finish line. After passing over starting line, the driver proceeds in order through each obstacle to the finish line. Points are added for each penalty and the lowest score is the event winner. Time allowed is for the entire course and will be used only to break a tie, unless the total time allowed is exceeded. In the event it becomes necessary to stop a competitor for any reason (unauthorized animal or person on the course, marker blown over, etc.), time will be stopped and the driver allowed to go back far enough to regain momentum before resuming the course. Timing starts when competitor reaches the point at which time was stopped.

The entire turnout (horse and vehicle) must pass through the markers. If a vehicle straddles a marker or if a ball atop a marker is dislodged, it is penalized as if marker were knocked over. If the entire turnout passes outside the markers, the competitor will be considered off course. If a part of an obstacle is disturbed or dislodged while completing that obstacle, the intended pattern must be completed as closely as possible.

Scoring

Penalties

- Dislodging a ball - 2 points
- Knocking over any element of an obstacle - 2 points
- Breaking into a canter (each offense) - 2 points
- Taking an obstacle out of sequence - Elimination
- Exceeding time limit - Elimination
- Failure to pass through start & finish markers - Elimination
- Receiving outside assistance - Elimination
- Driver Dismount
 - First Offense - 5 points
 - Second Offense - 10 points
 - Third Offense - Elimination

- Disobedience:
 - Rearing or balking anywhere on the course
 - Run-out (evading or passing an obstacle)
 - Refusal (stopping or reining back before an obstacle) If halt is prolonged or if the horse takes even a single step backward, a refusal is incurred; however, stopping before an obstacle followed IMMEDIATELY by driving cleanly through is not penalized.
- First Offense - 5 points
 Second Offense - 10 points
 Third Offense - Elimination

Sample Driving Obstacles

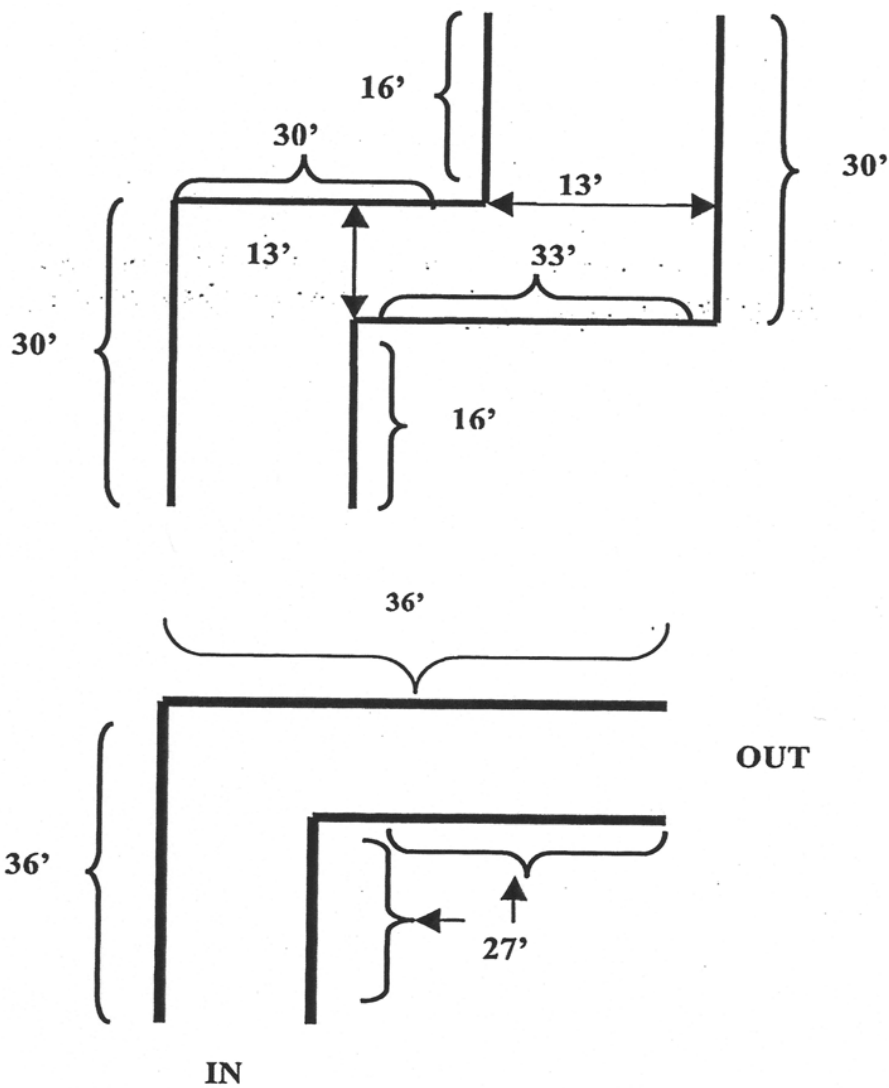

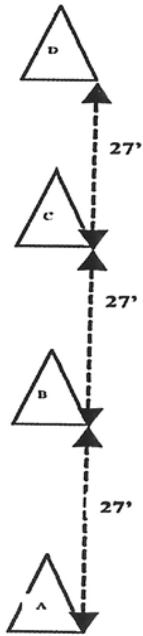
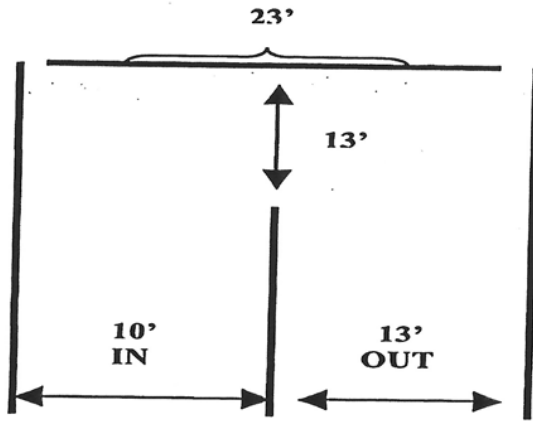
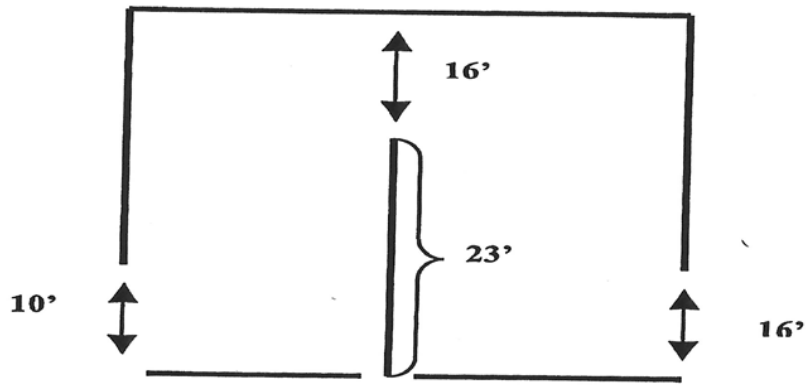

Sample Obstacle Driving Courses

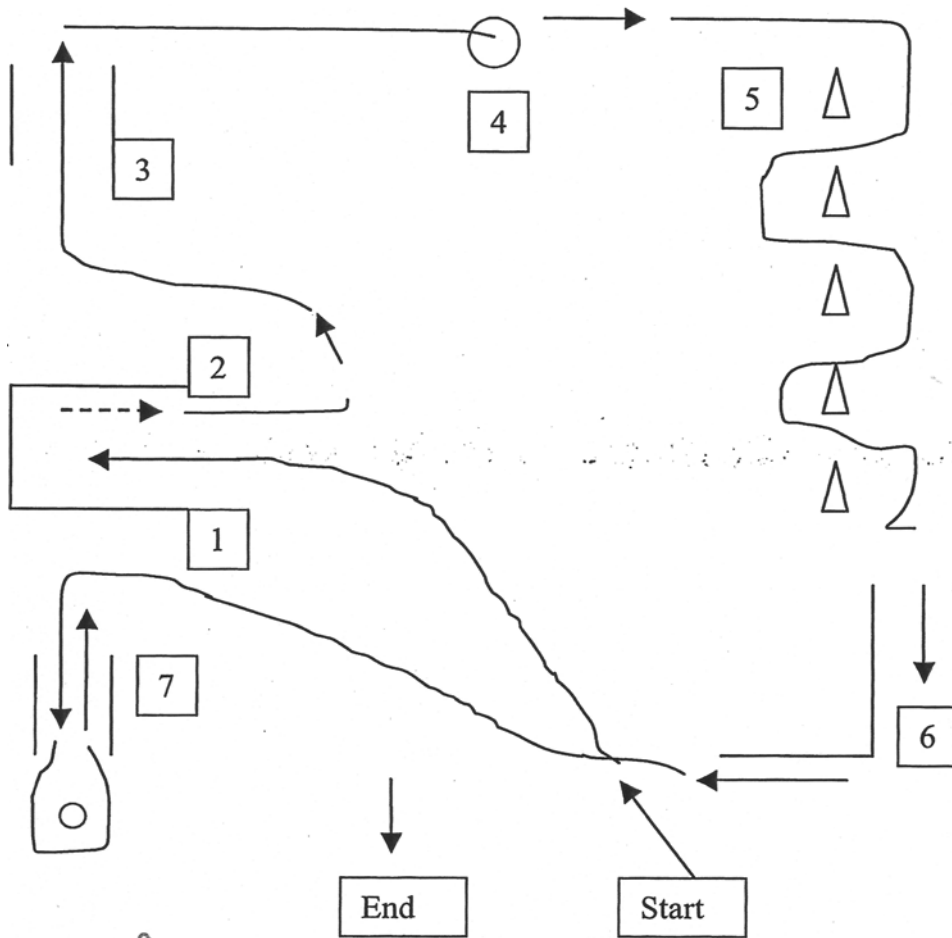

- Enter at walk, walk into “barn”, stop, hesitate, back out.
- 90 degree right wheel pivot
- Walk between 2 poles.
- Walk to and stop with right wheel inside circle, pivot 360 degrees
- Walk serpentine
- Running walk “L”
- Flat walk through poles, walk around barrel, flat walk out of poles
- Exit at flat walk

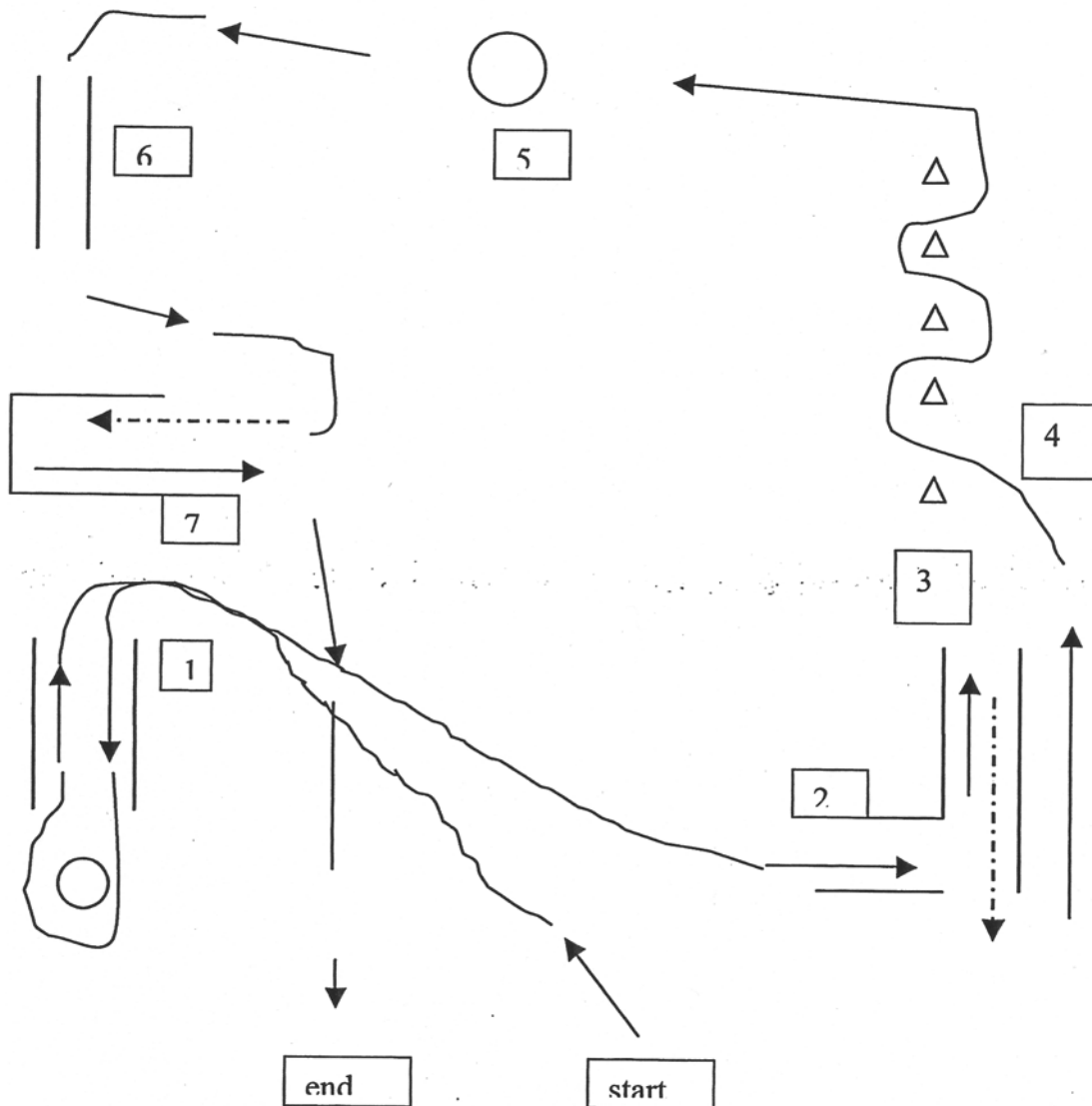

Enter at walk, flat walk into poles, walk around barrel, flat walk out of poles.
 Flat walk through "L"
 Stop and back out of long side of "L" Flat walk serpentine
 360 degree right wheel pivot on circle
 Walk with left wheel between poles
 Flat walk to "barn", 90 degree pivot, back into "barn", flat walk
 out and to finish.

OBSTACLE DRIVING – GAMBLER’S CHOICE

Participation

- A horse may not be entered more than once in the same class unless one driver is an adult and one driver is a youth.
- A youth under 14 years old may have an adult as a passenger but the adult may not touch the reins or assist the driver in any way. Such assistance would result in elimination.
- An adult that rides as a passenger may not afterward compete as a driver on the same course.

Turnout

Unless otherwise specified by show management, turnout should be the same as in pleasure driving.

Course

- Course consists of no more than 12 unnumbered obstacles and a clearly marked start/finish line.
- Course diagram must be posted at least 2 hours before the start of the class.
- Drivers must be allowed time to walk the course prior to the start of a class and inspect each obstacle. Horses are not allowed on course before the competition.
- Each obstacle is marked with a specific point value according to its degree of difficulty.
- Any obstacle that cannot be clearly marked must have a clearly drawn pattern explaining the correct entrance, exit and required path on the course diagram.

Event

Each driver attempts to score as many points as possible in a prescribed time and may attempt the obstacles in any order. After passing the starting line, the driver may drive through the obstacles in any order from any direction. Each obstacle may be negotiated twice, but not in succession. An obstacle may not be re-driven if it has been disturbed and no points will be awarded for an incorrectly completed obstacle. If the obstacle remains undisturbed, the driver may attempt it again. When the allowed time has elapsed, a whistle will be blown and the driver must then cross the finish line. If the driver has committed to an obstacle, he may complete that obstacle and receive the appropriate points then proceed immediately to the finish line. The winner will be determined on a high point basis. Time will decide ties. If a tie occurs in both points and time for first place, the winner will be decided by a drive-off.

EXAMPLES OF GAMBLERS CHOICE OBSTACLES

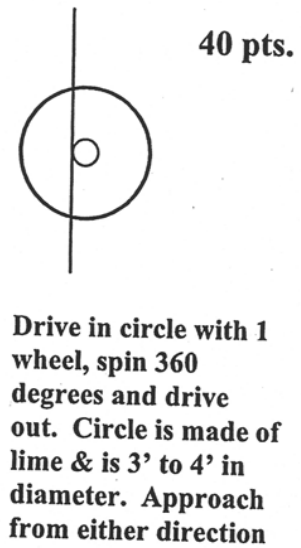
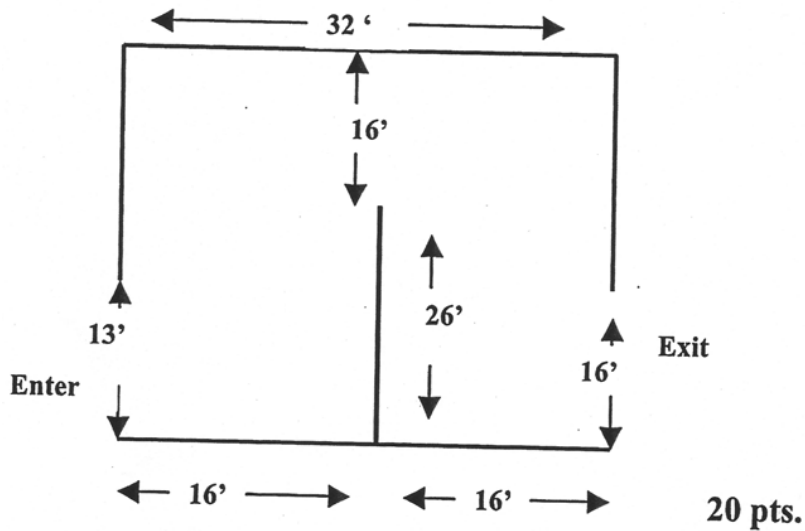
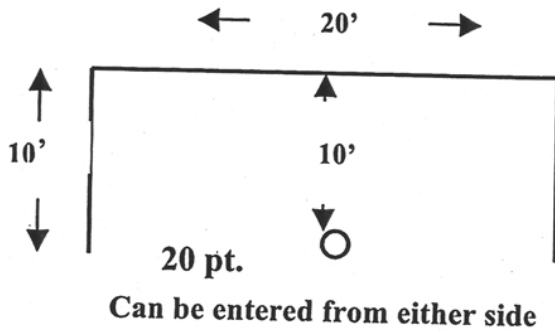
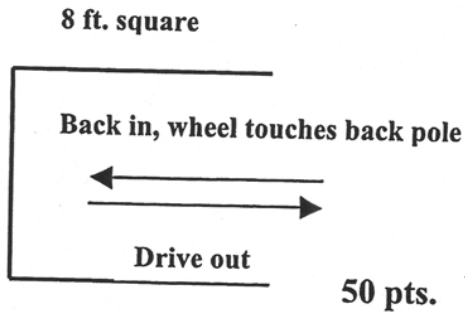
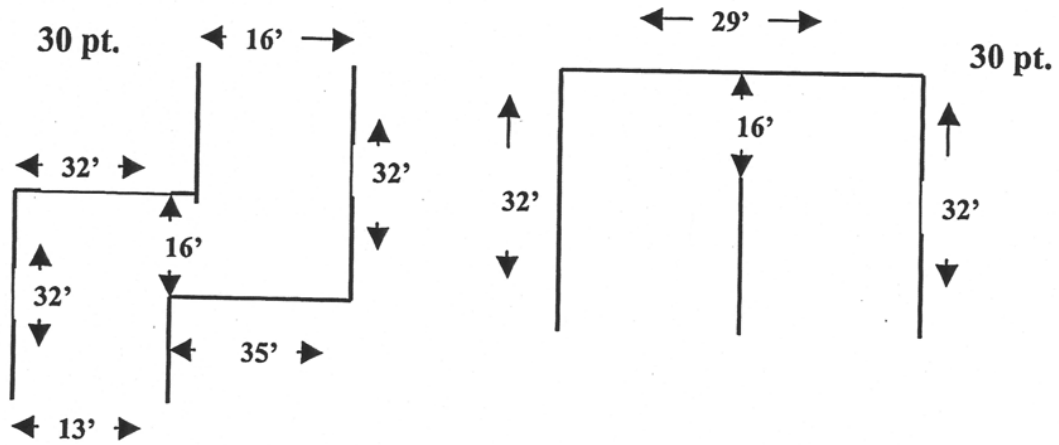

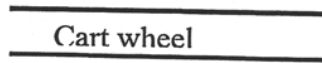
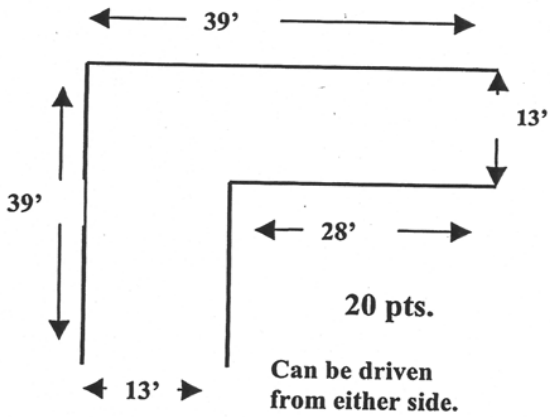

Can be driven from either side 30 pts.



Serpentine
All cones
25' apart

10 pts.

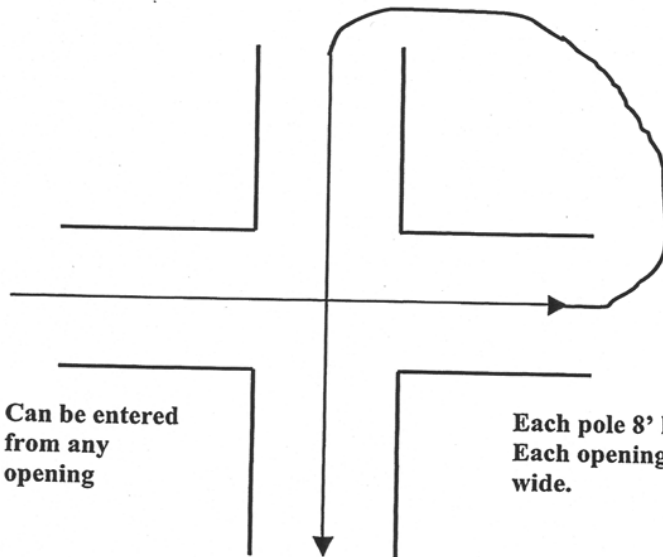

10 pts.

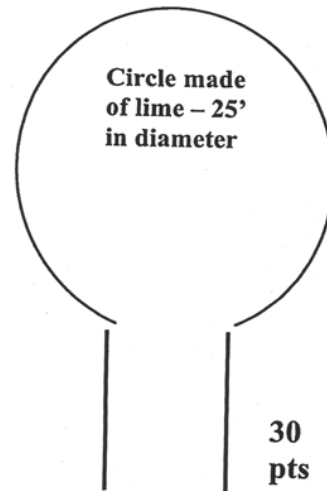

Drive into keyhole, drive around circle & drive out.

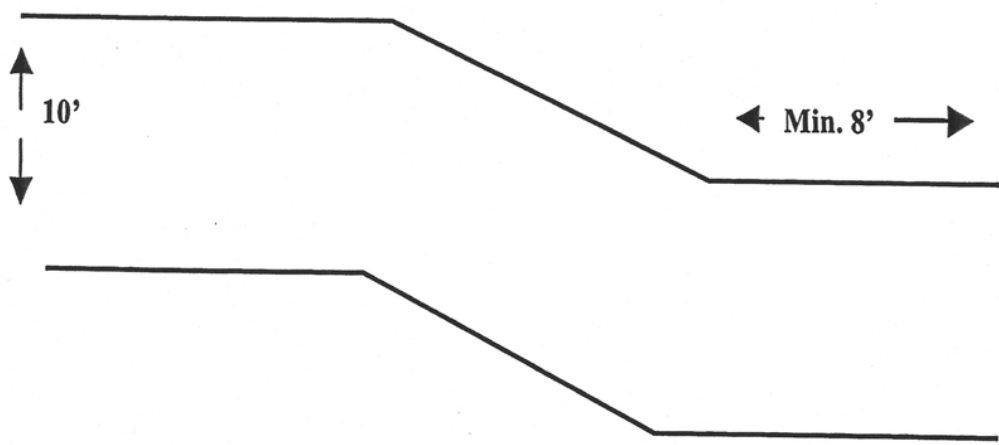
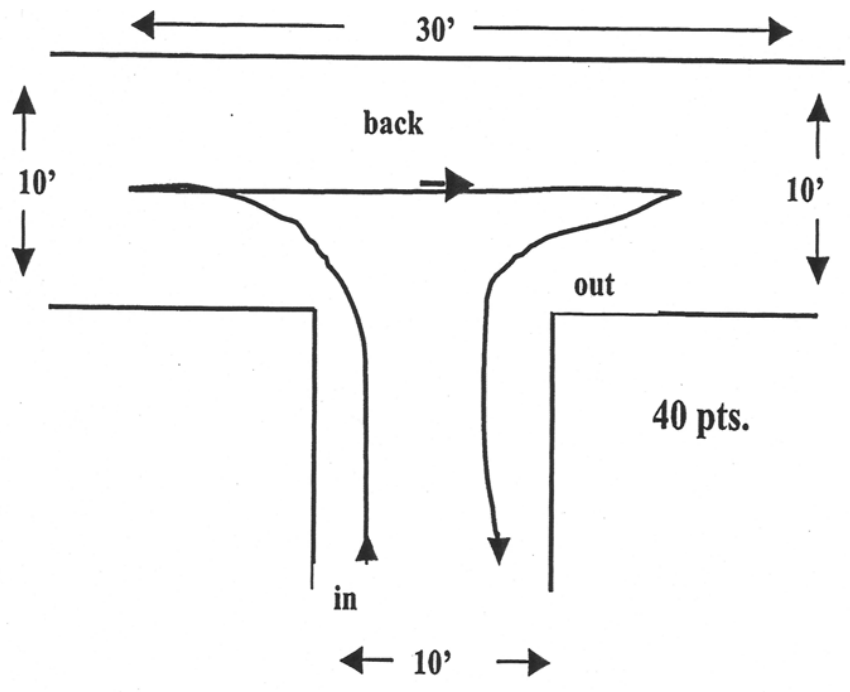

Approach from
either direction

EQUITATION DIVISION

Equitation is the art of riding horseback. In the equitation division, the exhibitor, as opposed to the horse, is judged on their seat, hands, their ability as it relates to performance of the horse, appointments of both horse and rider, ring showmanship, and overall presentation.

1. WALKING SEAT EQUITATION

a. CLASSES

- i. Walking Seat Equitation Exhibitors 11 and Under Specialty – must wear helmet
- ii. Walking Seat Equitation Exhibitors 12-17 (Canter or Specialty)
- iii. Walking Seat Equitation Championship (Canter or Specialty)
- iv. Walking Seat Equitation Adult Riders (Riders 18 years or older (Canter or Specialty))

b. GENERAL INFORMATION

- i It should be stressed that the required Equitation Walking Seat is a natural, coordinated and comfortable riding position and should in no way be rigid or exaggerated. Any stiffness or exaggeration of the rider should be penalized. Any bumping, pumping or extreme use of aids and body should also be penalized.
- ii A rider should convey the impression of effective and easy control, with the general appearance of being able to ride for a considerable length of time with pleasure. While the horse is not judged in Equitation, it is the exhibitor's responsibility to show the horse to the best of its' ability while maintaining proper form. The rider should perform all gaits using inconspicuous cues and the gifts of natural horsemanship.
- iii To show a horse well, rider should show himself or herself to the best advantage. Ring generalship shall be taken into consideration by the judge. The appearance, presentation and alertness of the rider and his/her mount should present an effortless and elegant image.

c. PERSONAL ATTIRE

- i. The rider of Walking Seat Equitation is to be judged on his/her skill and form on a horse. The horse and rider should be groomed to meticulous perfection. The rider should exercise good taste right down to the smallest, most meticulous detail. The rider is required to choose a neat, well-fitted habit with accompanying accessories within the guidelines based on tradition and present-day customs.
- ii. The two- or three-button (informal) saddle suit of a conservative color is correct for both day and evening. Jacket and Jodhpur pants should

be of the same fabric. Suggested colors include black, blue, grey, green, beige, or brown. Habits of conservative print or pinstripe are also allowed. Coordinated accessories are suggested. Vests may be worn and may either match or contrast with the habit color. Careful attention should be given to the fit of the habit. The coat length should be at least 3 inches below the fingertips when standing. The jodhpurs should be long enough to rest on the rider's boot top and cover the bottom of the boot heel when mounted. Only the toe of the boot should be visible. Jodhpur underpasses should always be worn. A moderate fullness is better than a suit that fits too snugly.

- iii. Girls should wear a matching or coordinated homburg or wide-brimmed saddle derby. Boys should wear a snap-brimmed hat. A properly fitting ASTM/SEI-approved riding helmet may be worn in place of derby or hat with no penalty. A four-in-hand tie matching or coordinating with the suit color should be worn. The shirt must be neat, clean, and well fitted. Boots should be of the English type in either calf or patent leather and should be polished and shined. Gloves of the same or coordinating color must be worn. English-type spurs (either blunt or small rowel or slip-ons) are optional. English riding whips are allowed.
- iv. The semi-formal or tuxedo-type one-button coat suit is suitable to be worn only after 6 P.M. The acceptable colors are dark blue, brown, gray or black, with collar or lapels of the same color. Top hat or homburg, dark bow tie, cummerbund, gloves and boutonniere complete the semi-formal outfit.
- v. The formal or tuxedo type one-button coat suit is also acceptable only after 6 P.M. The acceptable colors are dark blue, brown, gray or black, with collar or lapels of the same color. Top hat, cummerbund (or pique vest), white boutonniere, and matching or white bow tie and gloves complete the formal outfit.
- vi. The rider's hair must be neat and well-groomed. Girls with long hair should have it styled so the back number can be seen easily. Small post earrings may be worn.
- vii. Large earrings and bracelets, as well as large rings, do not belong in the show ring; neither do flying hair ribbons, corsages and large flowers. Nothing should detract from the genuine beauty of a well-trained horse and skilled rider.

d. TACK

- i. Bridles should be of the type commonly used by Walking Horses,

with a single pair of reins. Brow bands should match or coordinate with rider's attire and appointments. Colored brow bands are appropriate; however, rhinestones, etc., are not acceptable. Bridles with caveseons should be of black or brown leather. Clean, well-kept bridles and shining silver bits are far more attractive. Martingales or similar tie-downs are prohibited. Bit shanks should not exceed 9 ½ inches in length.

- ii. Saddles should be of the English cutback variety (either flat or deep seat) and of the correct size for the rider. They should be clean and well-kept with white girth and shining irons. Dressage, forward seat, Australian or Western saddles are prohibited.
- iii. Ribbons should be neatly attached at foretop and mane. Colors should blend well with rider's habit, brow band and color of horse. Braids should be of the straight-plaited variety with no butterflies or other ornamentations.

e. HAND POSITIONING

- i. The hands should be held in an easy position, waist or elbow high; over the withers of the horse, and exhibiting a light but natural hold of the reins
- ii. The hands should be in unison with the horse's mouth, showing adaptability as well as control. How and where the horse carries its head determines the height the hands are held above the horse's withers. Thumbs should be pointing in the ten and two positions of the clock. Arms should fall naturally from the shoulder, with the elbow on a vertical or slightly forward. At no time should the rider exhibit stiffness or excessive motion with his/her arms.
- iii. Hands and wrists should be flexible and not held extremely separated. (From the rider's view, the hands should be in a "V" shape, close enough for thumbs to touch when extended.) The fingers should be closed over reins, firm but not rigid, with enough pressure between thumb and index fingers to form a secure but light union with the horse. Closed (or crossed) reins may be used. The reins must be buckled, with the bight of the rein should be on the off-side.

f. BASIC POSITION

- i. When the rider is viewed from the side, a straight line should be drawn from the rider's ear, to shoulder, to hip, to heel. When viewed from the front, the rider should be balanced in the saddle, with shoulders square. Any tendency to lean to one side, sway, or lead with one shoulder should be penalized, as should excessive motion in

the saddle. The girth should be in front of the rider's leg at all times.

- ii. To obtain this position, the rider should sit comfortably in the middle of the saddle and find his/her center of gravity by sitting with a slight bend at the knees, without the use of the stirrups. At this position, the stirrups should fall at or slightly below the rider's ankle. While doing this, have stirrup leathers adjusted to fit so that irons will be under ball of foot with even pressure on entire width of sole and center of iron.
- iii. The foot position will be natural and comfortable if the knee and thigh are rolled inward and the heel is lower than the toes, with toes pointing straight ahead. From the front or rear view, the lower leg will be held naturally away from the horse, depending on the anatomy of the rider and the size of the horse. At no time should there ever be any space or daylight between the rider's knee and the saddle.
- iv. The rider should sit comfortably deep in the saddle, with his/her shoulders back and level, back flat, with ribs drawn out of the waist. Any tendency to exhibit a swayed or rounded back should be penalized.

g. POSITION IN MOTION

- i. The position in motion should be natural, coordinated and graceful, which is attained only with practice. The rider should maintain the proper form, using inconspicuous cues and natural aids to show his/her horse to the best of it's' ability with grace and elegance.
- ii. From the side view, a straight line can be drawn perpendicular to the ground through the rider's head, neck, shoulder, hip and heel. The rider's toe should never be any more forward than his/ her knee, with toes pointing straight ahead and heels below the stirrup irons.
- iii. Upper arms should fall naturally from the shoulders toward the hip bones, and should be flexible, never clutched to the body, extended forward or spread away from the body. Any stiffness or exaggeration should be penalized.
- iv. Hands should be in a comfortable waist-level position, depending on how and where the horse carries its head, showing adaptability as well as control. The use of the hands should be smooth and gradual, without jerking or pumping at any of the gaits, or jerks on the reins.

- v The rider should be looking forward, through the horse's ears, and be aware of his/her ring position and situation at all times. Every transition should be accomplished in a smooth, collected, and quiet manner, by both horse and rider. In the event a canter lead is missed, the rider must quickly recognize and correct the error.
- vi All flat shod entries must back in the line-up in classes or shows specifically designated for that discipline. All Walking Seat Equitation entries must reverse toward the rail.

h. CLASS PROTOCOL

- i. Each entry will enter the ring in a counterclockwise direction at each required gait, reverse and repeat each gait. The riders will then be lined up for inspection. The performance of the horse shall in no way be considered except as it relates to the manageability, control, and proper response to the Equitation rider.
- ii. Judges must walk the line-up in all Equitation classes, taking time to inspect each rider individually. (NOTE: all flat shod entries in flat shod classes are required to back.) At that time, the judge may ask each rider individually to perform from the following tests:
 - 1. All riders wearing English attire will be required to address his/her reins to check muscular control and sensitivity of the hands.
 - 2. Ask each entry three identical questions; one each about the anatomy of the horse, tack, and Equitation.
 - 3. Ask the exhibitor to drop and pick up his/her stirrups.
- iii. Upon completing the individual inspection, judges is **encouraged to** ask riders to perform pattern work. Pattern work should be used only in the event of a tie or close decision. The judge must always post the pattern one hour before the show starts, and the pattern must be announced during the class, prior to beginning the workout. Pattern work shall be used to ascertain the rider's skills in off the rail maneuvers. The riders must use the same correct form as in rail work, but with more difficult skill set.

Specific details that should be noted in pattern work include:

- (a) Efficiency in executing the pattern
- (b) Capacity to remain composed and responsive
- (c) The ability to exhibit accuracy in required gaits
- (d) The ability to perform required maneuvers in a uniform fashion
- (e) Smoothness through transitions

(f) Knowledge of correct canter leads and aids

- iv When using patterns, the judge must always remember that rail work and pattern work, each, will count 50% of the final score. Exhibitors who have NOT been selected to perform additional pattern work CANNOT be placed above exhibitors who have been selected to do so. Equitation classes that do not require the canter cannot be asked to execute a pattern that requires the canter.

2. STOCK SEAT EQUITATION - WALKING

a. CLASSES

- i Stock Seat Equitation Exhibitors 11 and Under Specialty – must wear helmet
- ii Stock Seat Equitation Exhibitors 12-17 (Canter or Specialty)
- iii Stock Seat Equitation Championship (Canter or Specialty)
- iv Stock Seat Equitation Adult Riders (Riders 18 years or older either Canter or Specialty)

b. PERSONAL APPOINTMENTS

- i Western Hat or ASTM/MSEI Approved Riding Helmet
- ii Long Sleeved Shirt with collar
- iii Vest or Jacket (Optional)
- iv Gloves
- v LongPants
- vi Boots
- vii Chaps (Coordinating, Optional)
- viii Spurs (Optional)
- ix Tie, Pin, or Scarf (Optional for Girls)
- x Tie or Bolo (Mandatory for Boys)

All riders and horses must be well groomed and exhibit good taste in their choice of appointments. The rider's hair must be neat and well groomed.

Girls with long hair should have it styled above the collar so the back number can be seen easily. Ultimately, the rider's appearance must be clean, workmanlike, and neat.

c. TACK

- i Equipment requirements must comply with the rules governing correct turnout for a Western pleasure horse.
- ii Bridles should be of the type commonly used by Western pleasure Walking Horses. Either split or romal reins are acceptable. Cavasons are prohibited. Bit shanks should not exceed 9 ½ inches in length. Horses five (5) years and under may be ridden with two hands provided that a snaffle bit or bosal is being used.
- iii Braids or colored brow bands are prohibited in Stock Seat Equitation.
- iv Saddles should be of the Western type. Silver mounted equipment should not take precedence over good working equipment. Australian Stock saddles are NOT permitted.
- v Saddle pads should match or contrast with the rider's appointments.

d. GENERAL INFORMATION

- i Riders will be judged on seat, hands, and the ability to control and show the horse. Results as shown by performance of the horse are NOT to be considered more important than the method used by the rider. Any stiffness or exaggeration of the rider should be penalized. Any bumping, pumping, or extreme use of aids and body should be penalized.
- ii A rider should convey the impression of effective and easy control, with the general appearance of being able to ride for a considerable length of time with pleasure. While the horse is not judged in Equitation, it is the exhibitor's responsibility to show the horse to the best of its' ability while maintaining proper form. The rider should perform all gaits using inconspicuous cues and the gifts of natural horsemanship.
- iii To show a horse well, the rider should show himself or herself to the best advantage. Ring generalship shall be taken into consideration by the judge. The appearance, presentation and alertness of the rider and his/her mount should present an effortless and elegant image.

- iv The rider should always use appropriate show ring etiquette. Any exhibitor not having his/her mount under sufficient control shall be dismissed from the ring. The fall of either the horse or the rider shall disqualify the entry, EXCEPT when the horse or rider falls because of contact interference from another rider or horse. In this situation, the entry at fault will be dismissed.

e. HAND POSITIONING

- i Both hands and arms shall be held in a relaxed, easy manner, with the shoulders back and down, and upper arm in a straight line with the body.
- ii The arm holding the reins should be bent at the elbow, forming a straight line from the elbow to the horse's mouth. The reins must be held in one hand and cannot be changed during the class.
- iii When using romal reins, the rider's off-hand shall be around the romal reins with at least 16 inches of rein between the hands. Wrists are to be relaxed, with thumb on top and fingers closed around the reins. The romal reins shall not be used forward of the cinch, or used to signal or cue the horse in any way. A finger between the reins is not permitted.
- iv When using split reins, a hand around the reins or index finger between the reins is permitted, but the free hand is not allowed to touch the reins.
- v Some movement of the arm is permissible, but excessive pumping will be penalized.
- vi Reins are to be carried immediately above or slightly in front of saddle horn. Only one hand is to be used for reining, and that hand shall not be changed.
- vii Reins should be carried so as to have light contact with the horse's mouth and at no time shall reins be carried more than a slight hand movement from the horse's mouth. Excessively loose or tight reins will be penalized.
- viii In the event a horse (5 years of age or younger) is shown with snaffle bit or bosal, it is acceptable for a rider to show with two hands on the reins.

f. BASIC POSITION

- i The rider should sit in the center of the saddle with legs under the rider forming a straight vertical line through the ear, center of the shoulder,

the center of hip and back of heel. When viewed from the front, the rider should be balanced in the saddle, with shoulders square. Any tendency to lean to one side, sway, or lead with one shoulder should be penalized, as should excessive motion in the saddle.

- ii Stirrup length should allow heels to be lower than toes, with a slight bend in knee and the toe directly under knee. The foot position will be natural and comfortable, with the knee and thigh rolled inward so that the heel is lower than the toes, with toes pointing straight ahead. From the front or rear view, the lower leg will be held naturally away from the horse, depending on the anatomy of the rider and the size of the horse. At no time should there ever be any space or daylight between the rider's knee and the saddle.
- iii The body should always appear comfortable, relaxed and flexible. The back should be nearly flat. A stiff and/or arched lower back should be penalized.
- iv The feet may be placed home in the stirrup, with boot heel touching the stirrup, or may be placed with ball of foot in the stirrup. Riding with toes only in stirrup will be penalized.

g. POSITION IN MOTION

- i The position in motion should be natural, coordinated and graceful, which is attained only with practice. The rider should maintain the proper form, using inconspicuous cues and natural aids to show his/her horse to the best of its' ability with grace and elegance. All movements of the horse should be governed by the use of imperceptible aids.
- ii From the side view, a straight line can be drawn perpendicular to the ground through the rider's head, neck, shoulder, hip and heel. The rider's toe should never be any more forward than his/ her knee, with toes pointing straight ahead. The riders' weight should be settled into his/her heels.
- iii Upper arms should fall naturally from the shoulders toward the hipbones, and should be flexible, never clutched to the body, extended forward or spread away from the body. Any stiffness or exaggeration should be penalized.
- iv Hands should be in a comfortable waist-level position, depending on how and where the horse carries its head, showing adaptability as well as control. The use of the hands should be smooth and gradual, without

jerking or pumping at any of the gaits, or jerking on the reins.

- v The rider should be looking forward, through the horse's ears, and be aware of his/her ring position and situation at all times. Every transition should be accomplished in a smooth, collected, and quiet manner, by both horse and rider. In the event a canter lead is missed, the rider must quickly recognize and correct the error.
- vi All Stock Seat Equitation entries must reverse away the rail (toward the judge), and back in the line up.

h. CLASS PROTOCOL

- i Each entry will enter the ring in a counterclockwise direction, complete each required gait, reverse and repeat each gait as called. The riders will then be lined up for inspection. The performance of the horse shall in no way be considered except as it relates to the manageability, control, and proper response to the Equitation rider.
- ii Judges must walk the line-up in all Equitation classes, taking time to inspect each rider individually. (NOTE: All Stock Seat Equitation exhibitors are required to back.) At that time, the judge **is encouraged to** ask each rider individually to perform from the following tests:
- iii Ask each entry three identical questions; one each about the anatomy of the horse, tack, and Equitation.
- iv The exhibitor may be asked to back clear of the line up and execute a 360 degree neck reined turn, either to the right or left at the exhibitor's discretion.
- v Upon completing the individual inspection, judges may ask riders to perform pattern work. Pattern work should be used only in the event of a tie or close decision. The judge must always post the pattern one hour before the show starts, and the pattern must be announced during the class, prior to beginning the workout. Pattern work shall be used to ascertain the rider's skills in off the rail maneuvers. The riders must use the same correct form as in rail work, but with a more difficult skill set.
- vi Specific skills that should be noted in pattern work include:
 - a. Efficiency in executing the pattern
 - b. Capacity to remain composed and responsive
 - c. The ability to exhibit accuracy in required gaits
 - d. The ability to perform required maneuvers in a uniform

fashion

- e. Smoothness through transitions
- f. Knowledge of correct canter leads and aids

vii When using patterns, the judge must always remember that rail work and pattern work, each, will count 50% of the final score. Exhibitors who have NOT been selected to perform additional pattern work CANNOT be placed above exhibitors who have been selected to do so. Stock Seat Equitation classes that do not require the canter cannot be asked to execute a pattern that requires the canter.

Any patterns used should be posted 1 hour before class.

The following patterns are general examples, other patterns may be used:

Walking Seat Equitation Pattern 1

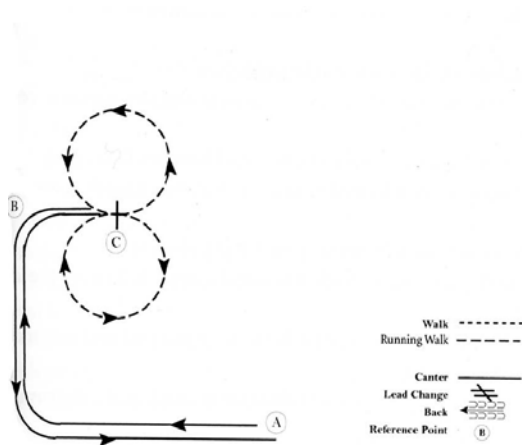

Begin at the mid-point of the in-gate end of the arena (A).

1. Canter to the left, around the curve and to the mid-point of the straightaway (B)
2. Without halting, make a turn to the right, and continue 1/4 of the way across the arena (C). Stop briefly.
3. Running walk a Figure 8, the first circle clockwise and the second circle counter clockwise. Stop briefly at (C).
4. Reverse and canter on the left lead to the rail (B). Turn left and continue to the end of the straightaway, around the curve and to the midpoint of the straightaway (A).

Walking Seat Equitation Pattern 2

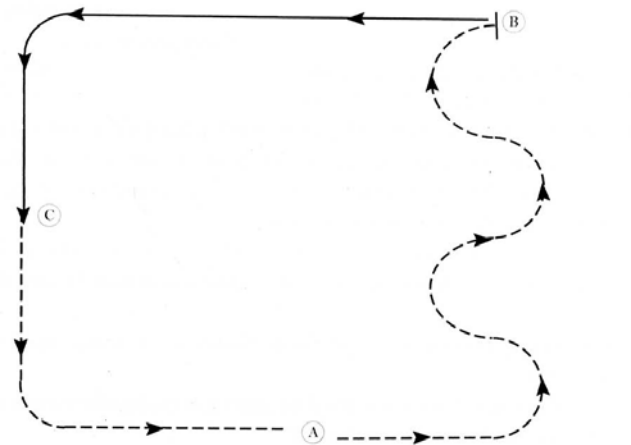

Begin at the mid-point of the in gate end of arena (A).

1. Begin test at Running Walk (A) to the right and perform a serpentine consisting of four half-circles.
2. Stop briefly and reverse (B).
3. Canter along the rail, around the curve to the midpoint of the straightaway (C).
4. Go directly into Running Walk, continue to the end of the straightaway, around the next curve and to the exit (A).

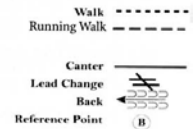

Stock Seat Equitation Pattern 1

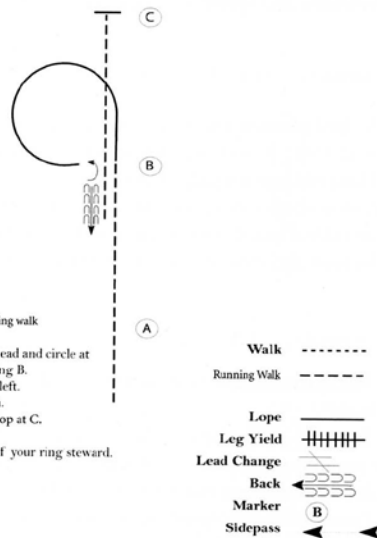

Begin before A at a running walk

1. Running Walk A to B
2. At B, lope on the left lead and circle at B as shown. Stop facing B.
3. Turn 1/4 turn to the left.
4. Back one horse length.
5. Running Walk to C. Stop at C.

Follow the instructions of your ring steward.

Stock Seat Equitation Pattern 2

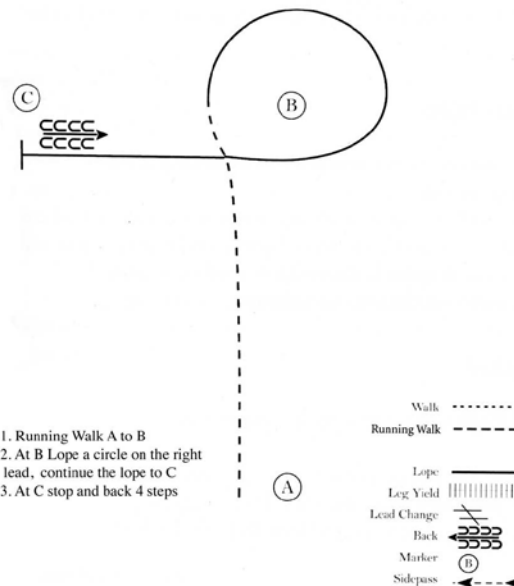

1. Running Walk A to B
2. At B Lope a circle on the right lead, continue the lope to C
3. At C stop and back 4 steps

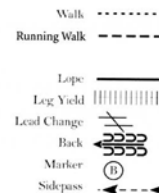

WALKING SEAT EQUITATION – PATTERN 1

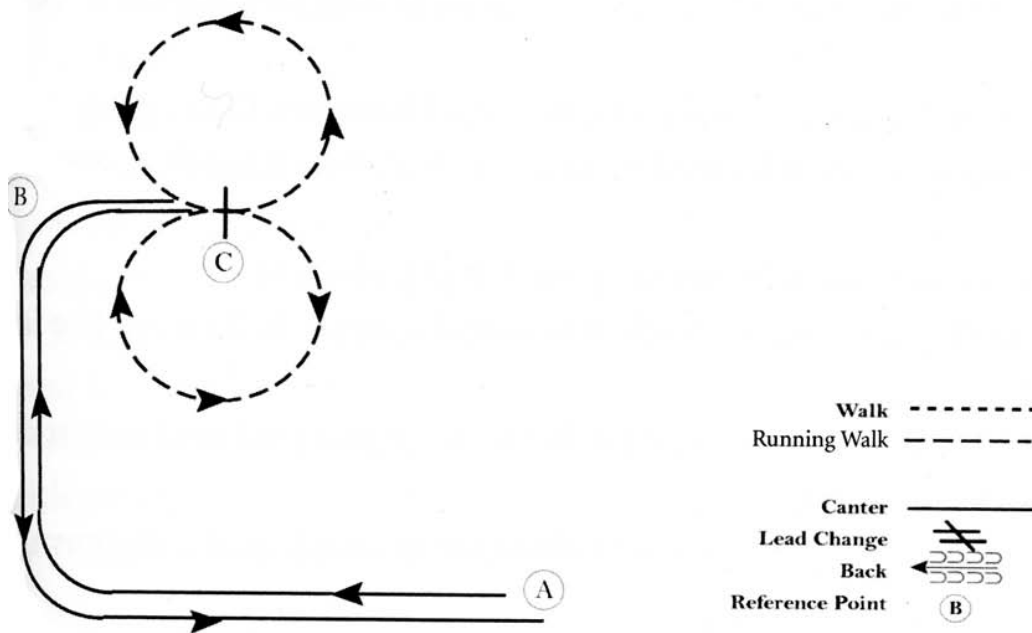

Begin at the mid-point of the in-gate end of the arena (A).

1. Canter to the left, around the curve and to the mid-point of the straightaway (B)
2. Without halting, make a turn to the right, and continue 1/4 of the way across the arena (C). Stop briefly.
3. Running walk aFigure 8, the first circle clockwise and the second circle counter clockwise. Stop briefly at (C).
4. Reverse and canter on the left lead to the rail (B). Turn left and continue to the end of the straightaway, around the curve and to the midpoint of the straightaway (A).

WALKING SEAT EQUITATION – PATTERN 2

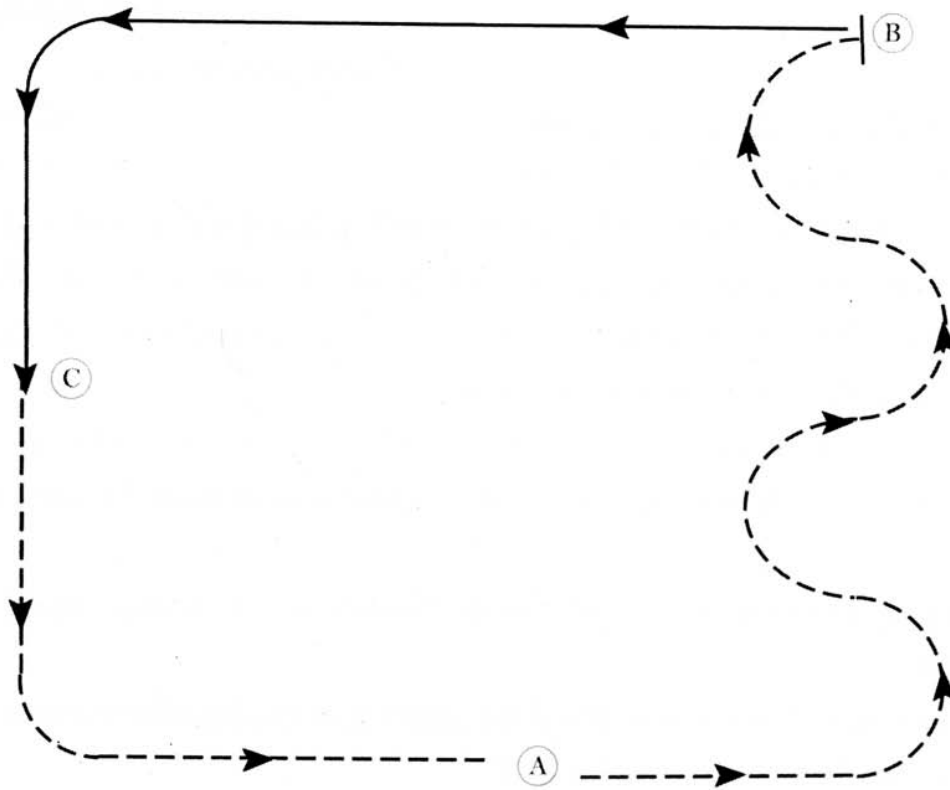

Begin at the mid-point of the in gate end of arena (A).

1. Begin test at Running Walk (A) to the right and perform a serpentine consisting of four half-circles.
2. Stop briefly and reverse (B).
3. Canter along the rail, around the curve to the midpoint of the straightaway (C).
4. Go directly into Running Walk, continue to the end of the straightaway, around the next curve and to the exit (A).

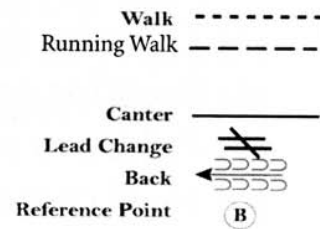

STOCK SEAT EQUITATION – PATTERN 1

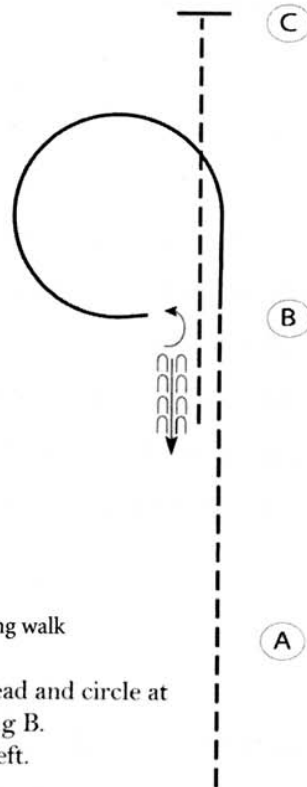

- Begin before A at a running walk
1. Running Walk A to B
 2. At B, lope on the left lead and circle at B as shown. Stop facing B.
 3. Turn 1/4 turn to the left.
 4. Back one horse length.
 5. Running Walk to C. Stop at C.
- Follow the instructions of your ring steward.

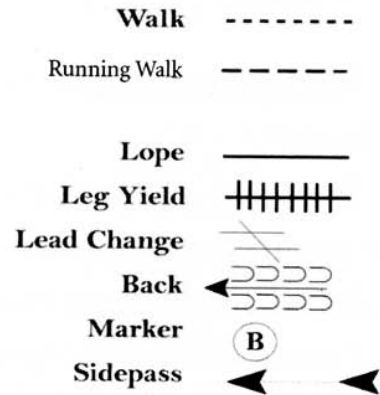

STOCK SEAT EQUITATION –PATTERN 2

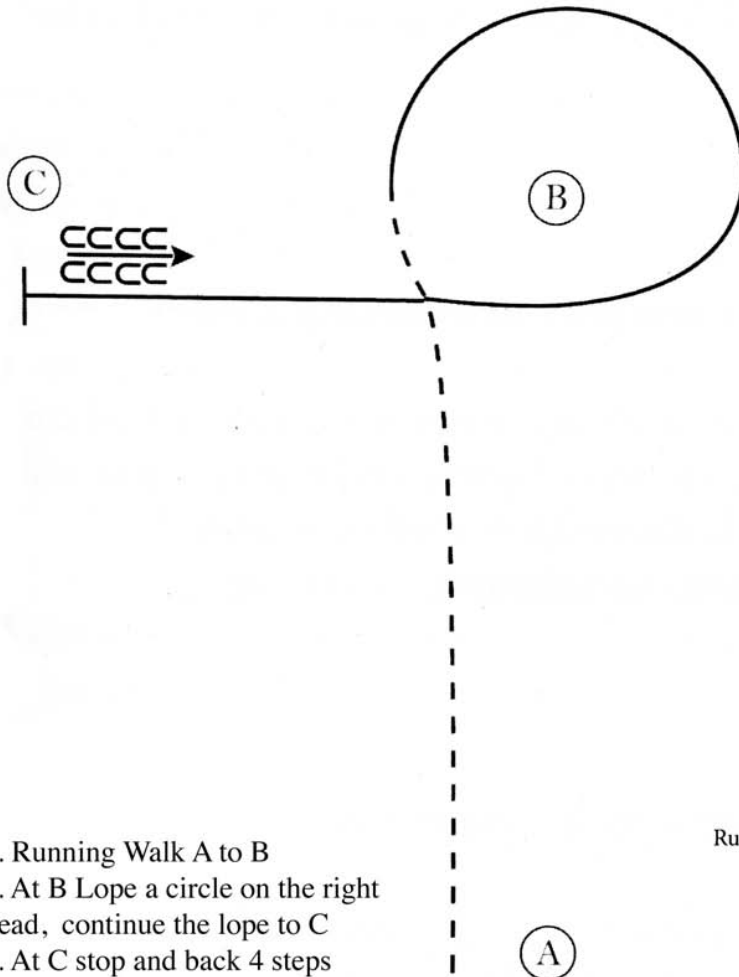

1. Running Walk A to B
2. At B Lope a circle on the right lead, continue the lope to C
3. At C stop and back 4 steps

Walk
Running Walk	-----
Lope	—————
Leg Yield	
Lead Change	—/—
Back	← C C C C C C C C
Marker	(B)
Sidepass	←-----→

GAME CLASSES

Cavesons are allowed on all horses in game classes.

Quick change bridles are reins are allowed in Game Classes.

Game classes are defined as any non-timed event depending on a combination of skill, luck and/or process of elimination

WATER GLASS

Riders hold a full glass of water while horses perform the flat walk and running walk both ways of the ring. A noticeable change in speed between the flat walk and the running walk is mandatory, and the horse must be excused if a distinct change in speed is not performed. The entry with the most water left in his glass wins the class. In case of a tie, a canter may be required, as well as other maneuvers such as backing, circling, figure-8, changing glass from one hand to the other, etc. One hand only is to be used in holding the glass, out and away from the body of horse and rider. The hand may not cover the top of the glass.

EGG AND SPOON

Riders carry an egg balanced on a spoon while horses perform the flat walk and running walk both ways of the ring. The spoon must be held so that the rider's thumb does not touch the egg. A noticeable change in speed between the flat walk and the running walk is mandatory, and the horse must be excused if a distinct change in speed is not performed. As soon as an egg falls, the rider is out and should pull into the center of the ring. The last rider to drop his egg is the winner. In case of a tie, a canter may be required, as well as other maneuvers such as backing, circling, figure-8, changing spoon from one hand to the other, etc.

RIDE-A-BUCK

Contestants ride bareback with a dollar bill beneath their seat, thigh or under their knee at the three gaits of the Tennessee Walking Horse. (Flat walk, running walk, canter) In case of a tie, other maneuvers may be added, such as backing, 360 degree turn, etc. As a variation, two dollar bills may be used, one under each thigh or knee.

MUSICAL SACKS

Sacks, cones, etc., are placed at intervals around the ring, one less than there are entries. There should be a cone placed at each end of the ring to prevent contestants from cutting across the ring. Music is played, or if music is not available as whistle may be blown as a signal. Riders proceed around the ring as the music plays, passing on the outside of the cones. When the music stops or the whistle blows, riders must ride forward to a sack or cone, dismount and stand on the sack or touch the cone. The rider left without a sack or cone is eliminated, a sack or cone is removed and the game continues until only one rider is left. The music should not begin again until

all riders are mounted.

MUSICAL CHAIRS

This is a team competition. Each team has 2 horses and riders. Chairs are placed in a large evenly spaced circle in center ring, one less chair than entries. The teams take their place on the rail and ride at a flat walk or running walk. Music is played, or if music is not available a whistle may be blown as a signal. When the music stops or the whistle blows, one person from each team dismounts, rushes for a chair and sits down in it while his teammate holds his horse. The rider who does not get a chair is eliminated along with his teammate, a chair is removed and the game continues until only two teams are left. The music should not resume until all riders are remounted. In order to keep the game interesting, teams should be ordered to stay near the rail or wall so there will be a real footrace when the music stops.

BACK TO BACK

Horses enter the ring at a flat walk and proceed counterclockwise around the ring. Two riders are on each horse, one facing forward and one facing the rear of the horse. Horses work at a flat walk and running walk. When asked to reverse directions, riders must switch positions without dismounting. Any rider who touches the ground will disqualify that entry. Horses then work at a flat walk and running the second way of the ring and line up. Qualified entries are judged as you would judge a country pleasure class.

BABY BOTTLE RACE

Horses enter the ring carrying two riders. Rider in the front is holding a baby bottle filled with water. At the signal from the announcer, the rider in the front must hold the bottle over his shoulder and the rider in the back must drink the water without touching the bottle at any time. Bottle **MUST** be held over the shoulder, not under the arm or out to the side and second rider must not touch the bottle except with his mouth. The horse continues around the ring and the first rider to finish all the water is the winner. Other placing's will be in the order in which the contestants finish their bottle.

HALTER DIVISION

See WHOA Official Flat Shod Rulebook page 38 and page 39

NOTES: _____

NOTES: _____

BASIC REINING

REVISED 11/25/2017

REINING

General

Reining is a judged event designed to show the athletic abilities of the horse and rider combination. In reining competition, contestants are required to run one of several patterns. Each pattern can include small slow circles, large fast circles, flying lead changes, rollbacks over the hocks, a series of 360o spins done in place, and sliding stops. The pattern should be selected by the judge or show management and be posted a minimum of one hour before the class. Show management has the option of including the pattern as a part of the show program. Each contestant will perform the required pattern individually and separately. All horses will be judged immediately upon entering the arena. Any faults incurred prior to commencement of a pattern will be scored accordingly. All deviations from the exact written pattern must be faulted according to the severity of the deviation. Credit will be given for smoothness, finesse, attitude, quickness, and authority in performing the various maneuvers while controlling speed.

Tack and Equipment

Western tack and attire are required. Properly worn ASTM/SEI approved headgear is recommended for all exhibitors and shall not be penalized. Silver tack may be used but shall not be given preference over good working equipment. Saddle is to be western type and must fit both the animal and the rider. Bridle is to be western style. A curb may be either leather or chain, must be western style, and must be at least ½ inch wide and lay flat against the animal's jaw. Spilt or romal reins must be used. Junior horses five years old and under may be ridden in a snaffle bit or bosal and may use two hands on the reins.

Optional Tack: Breast strap, hobbles on saddle when romal is used, skid boots, splint boots, polo wraps, covered stirrups or tapaderos.

Prohibited Tack: Mechanical hackamore, draw reins, tie downs, running or other types martingales, cavesson noseband, crops, bats, whips.

Attire: Riders shall wear western style long pants, western style long sleeve and collared shirt, a western hat or safety helmet, and western boots.

Optional Attire: Chaps, spurs, coats, vest, jacket, gloves.

Scoring

Scoring will be on the basis of 0 to 100 with 70 denoting an average performance. Points will be added or subtracted from the maneuver score on the following basis with points ranging from plus 1 ½ to minus 1 ½: -1 ½ extremely poor; -1 very poor; -1/2 poor; 0 average; +1/2 good; +1 very good; + 1 ½ excellent. Maneuver scores are to be determined independently of penalty scores.

The following will result in disqualification – no score:

- a. Abuse of an animal

- b. Illegal equipment
- c. Exhibitor disrespect or misconduct
- d. Any unsafe act

The following will result in a score of 0:

- a. Use more than index finger or first finger between reins
- b. Use of two hands on reins (exception on junior horses, five and under, being ridden with a snaffle bit or a bosal) or changing hands.
- c. Failure to complete pattern as written
- d. Performing the maneuvers other than in specified order
- e. Balking or refusal
- f. Running away
- g. Fall by horse or rider
- h. Dropping rein while horse is moving
- i. Breaking gait in excess of one-half circle or one-half length of arena
- j. Overspins of more than ¼ turn

If an exhibitor is assigned a score of zero, they are included in the group considered for awards. That is, if there are fewer horses in the class than there are placings, an exhibitor assigned a zero score may be awarded a ribbon, but cannot be placed over an exhibitor with no zero score. Disqualified exhibitors must not receive any award, no matter the number of entries.

The following will result in a five (5) point penalty:

- a. Spurring in front of cinch
- b. Using either hand to instill fear or praise
- c. Holding saddle with either hand
- d. Blatant disobedience including kicking, biting, bucking, rearing, and striking

The following will result in a two (2) point penalty:

- a. Breaking of gait
- b. Freeze up in spins or rollbacks
- c. On walk-in patterns, failure to stop or walk before executing a canter departure
- d. If a horse does not completely pass the specified marker before initiating a stop position
- e. Flat walk beyond two strides but less than one-half circle or one-half the length of the arena when starting a circle or exiting a rollback
- f. In patterns requiring a run around the end, out of lead for more than one-half turn

The following will result in a one (1) point penalty:

- a. In circles and figure eights, the penalty for being out of lead is accumulative and the judge must deduct one penalty point for each quarter of the circumference of a circle, or any part thereof, that a horse is out of lead
- b. Over and under spinning up to one-fourth of a turn
- c. Delayed change of lead from one stride to ¼ circumference of a circle
- d. In patterns requiring a run around the end, out of lead for one-half turn or less

The following will result in a one-half (1/2) point penalty:

- a. Starting circle at a flat walk or exiting rollbacks at any gait other than a canter up to two strides
- b. Over or under-spinning up to one-eighth (1/8) of a turn
- c. Failure to maintain a minimum of twenty (20) feet from wall or fence when approaching a stop and/or rollback

Faults against the horse to be scored accordingly, but not to cause disqualification:

- a. Opening mouth excessively when wearing bit
- b. Excessive jawing or head raised when stopping
- c. Lack of smooth straight stops, haunches-bouncing or sideways stop
- d. Refusing to change leads
- e. Anticipating signals
- f. Stumbling
- g. Backing sideways
- h. Knocking over marker

Faults against the rider to be scored accordingly, but not to cause disqualification:

- a. Loosing stirrup
- b. Failure to run circles or figure eights within the markers is not considered a fault depending on arena condition and size; however, failure to go beyond markers on rollbacks and stops is considered a fault

The judge shall have the authority to remove any contestant who shows disrespect or misconduct as to portray himself or the competition in an unprofessional manner.

Pattern:

The following patterns are to be worked as stated in writing, not drawn. Exhibitors who do not complete the pattern AS WRITTEN shall be “off course”, and shall be disqualified.

Markers will be placed on or at the wall or fence of the arena as follows:

- a. At the center of the arena
- b. At least 50 feet from each end wall

Where the pattern designates a stop beyond marker, the horse should begin its stop after they pass the marker.

Reining patterns and guidelines, modified for the Walking Horse, reproduced with permission NWH, NRHA, TWHBEA, and AQHA.

REINING PATTERN NUMBER 1

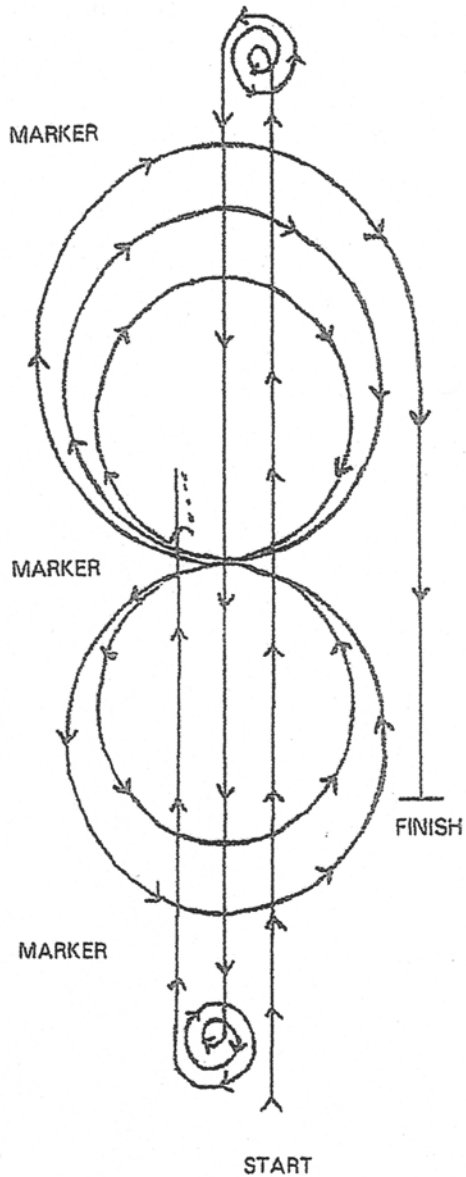

1. Run to the far end of the established pattern area, stop and do 2 ½ spins to the left, no hesitations.
2. Run to the opposite ends of the pattern, stop and do 2 ½ spins to the right, no hesitation.
3. Run past center of pattern, do a sliding stop, no hesitation: back over slide track to center, hesitate.
4. Make a ¼ pivot to the left to face left wall, hesitate.
5. Begin on right lead and make 2 circles to the right, the first small and slow the second large and fast. Change leads at center of arena
6. Make 2 circles to the left, the first small and slow the second large and fast. Change leads at center of arena.
7. Begin a large fast circle to the right do not close the circle but run straight down side past the center, do a sliding stop. (Stop to be at least 20 feet from wall or fence).
8. Walk to judge and stop and remain for inspection until dismissed.
9. The bridle may be dropped at judge's discretion.

The arena should be approximately 50 feet by 150 feet. Markers should be placed on the fence or wall to indicate the length of the pattern.

REINING PATTERN NUMBER 2

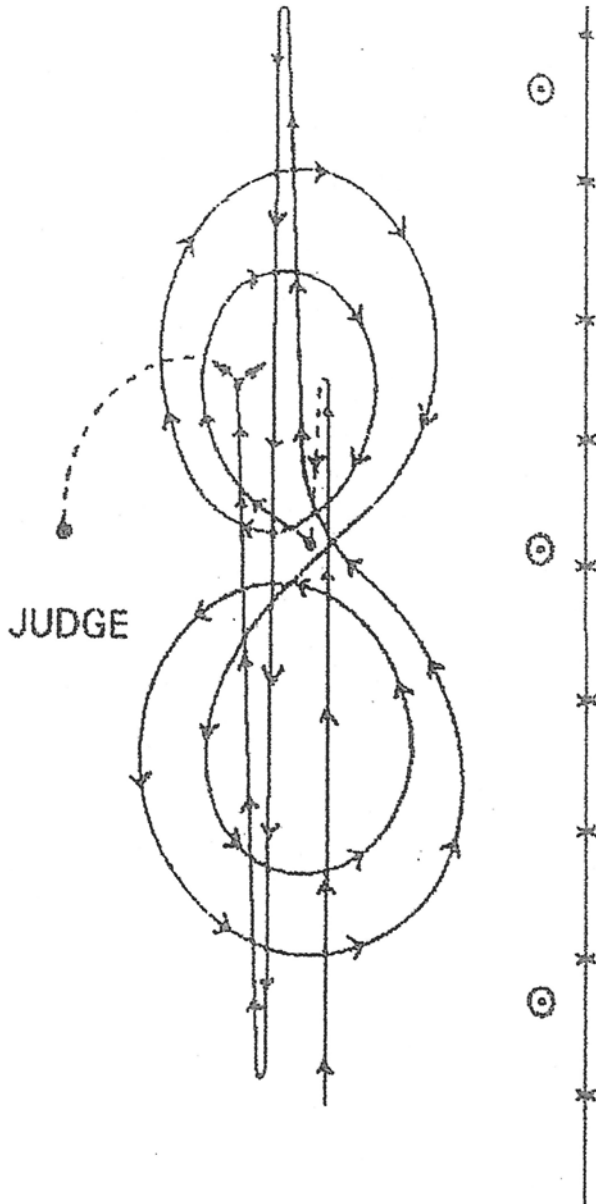

1. Run with speed, past center marker.
2. Stop and back up to center of pattern.
3. Settle horse for approximately 10 seconds. Start lope. Circles should be made inside end markers.
4. Ride 2 circles to the right, the first small and slow, the second large and fast.
5. Ride 2 circles to the left, the first small and slow, the second large and fast.
6. Left roll back over hocks (should be made past far end marker).
7. Right roll back over hocks (should be made past far end marker)
8. Stop (should be made past center marker), let horse settle, then in approximate area of stop, do the pivots.
9. Pivot right or left no more than 90 degrees.
10. Pivot opposite direction, no more than 180 degrees
11. Walk to judge and stop for inspection until dismissed.
12. The bridle may be dropped at the judge's discretion.

The arena should be approximately 50 feet by 150 feet. Markers should be placed on the fence or wall to indicate the length of the pattern

REINING PATTERN NUMBER 3

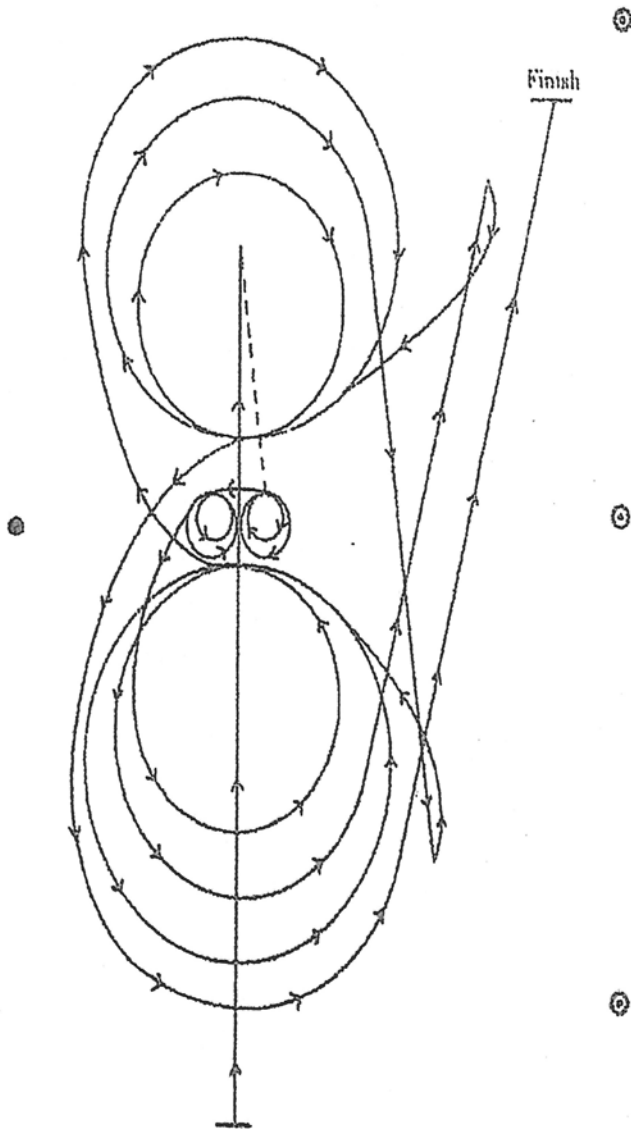

1. Run past center of established pattern area and do a sliding stop.
2. Back immediately to center of pattern, hesitate.
3. Do 2 spins to the right.
4. Do 2 and a quarter spins to the left, hesitate.
5. Beginning on left lead make a small, slow circle, then begin a large fast circle. Do not close this circle, but run straight down the side past center marker and do a right roll back at least 20 feet from fence or wall.
6. Continue back to center of pattern, horse should be on right lead at center, make a small slow circle to the right, then begin a large, fast circle. Do not close this circle, but run straight down the side past center and do a left rollback at least 20 feet from wall or fence.
7. Continue back to center of pattern, horse should be on the left lead at center.
8. Make a large fast circle to the left at center of pattern, change leads and make a large fast circle to the right at center of arena – change leads and begin a large, fast circle to the left. Do not close this circle, but run straight down the side past center marker and do a sliding stop at least 20 feet from fence or wall.
9. Walk to the judge for inspection until dismissed.
10. The bridle may be dropped at the

The arena should be approximately 50 feet by 150 feet. Markers should be placed on the fence or wall to indicate the length of the pattern.

REINING PATTERN NUMBER 4

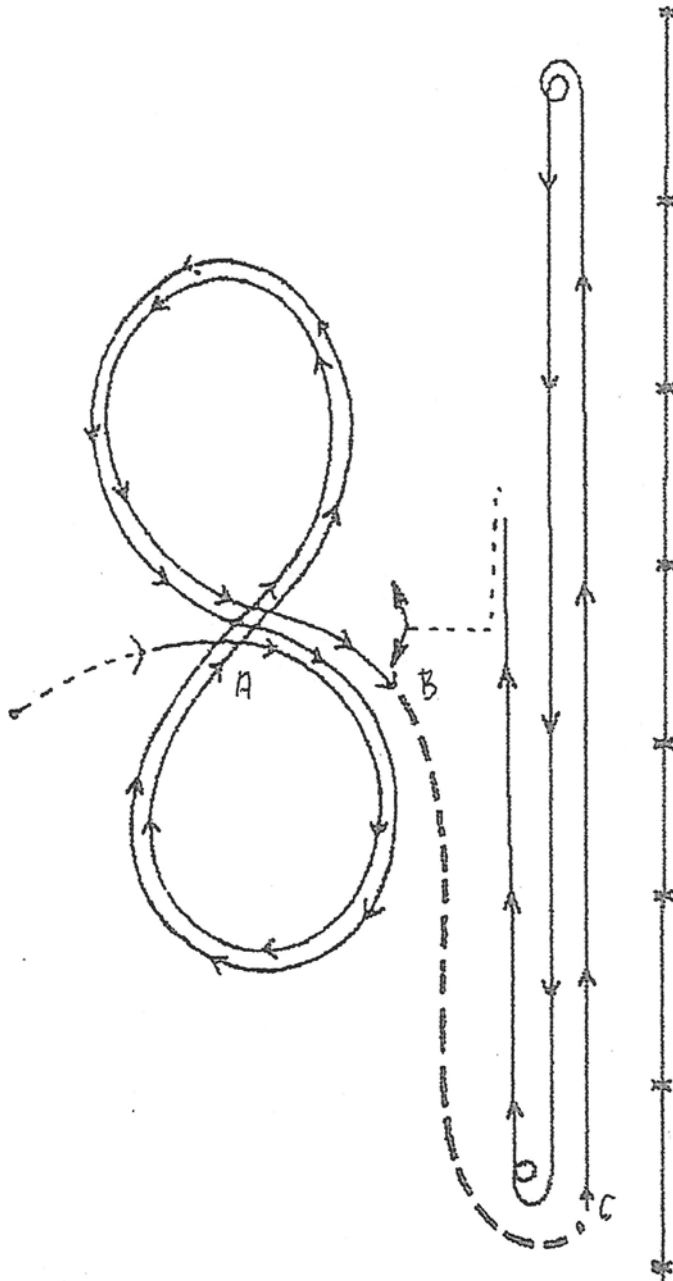

1. Begin work to the right.
2. First figure eight slow.
3. Second figure eight, faster (lead change must take place at Point A).
4. Proceed from Point B to Point C at a flat walk or running walk.
5. Begin run.
6. Sliding stop.
7. Turn away from the rail, do a spin and a half with no hesitation; begin run.
8. Sliding stop.
9. Turn away from the rail, do a spin and a half with no hesitation; begin run.
10. Sliding stop.
11. Back over slide marks. Face judge, walk a few steps.
12. Pivot right or left, no more than 90 degrees.
13. Pivot the opposite direction, no more than 180 degrees.
14. Pivot in the direction taken in #12, no more than 180 degrees.
15. Walk to judge for inspection until dismissed.
16. The bridle may be dropped at the judge's discretion.

The arena should be approximately 50 feet by 150 feet. Markers should be placed on the fence or wall to indicate the length of the pattern.

REINING PATTERN NUMBER 5

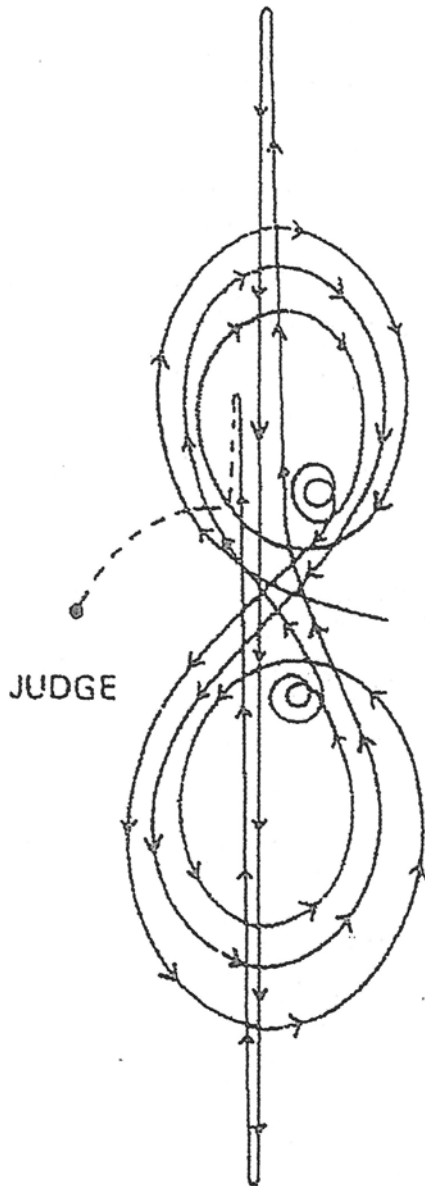

1. Starting in the center of the established pattern area, make a large, fast circle to the right.
2. Draw the circle down to a small circle until you reach the center of the established pattern area – stop.
3. Do a double spin to the inside of the small circle in the center of the established pattern area. At the end of spins, horse should be facing the left wall, slight hesitation.
4. Begin on left lead and make a large fast circle.
5. Then a small circle again drawn down to the center of the established arena – stop – no hesitation on these stops.
6. Do a double spin to the inside of the small circle, slight hesitation – horse to be facing left wall.
7. Begin on right lead and make a fast figure eight over the large circle – change leads.
8. Run to far end of established pattern area and do a left roll back.
9. Run to the opposite end of the established pattern area and do a right roll back.
10. Run back past the center of established pattern area and do a sliding stop. Hesitate.
11. Back over the slide tracks.
12. Finish; walk to judge for inspection and dismissal.
13. The bridle may be dropped at the judge's discretion.

The arena should be approximately 50 feet by 150 feet. Markers should be placed on the fence or wall to indicate the length of the pattern.

REINING PATTERN NUMBER 6

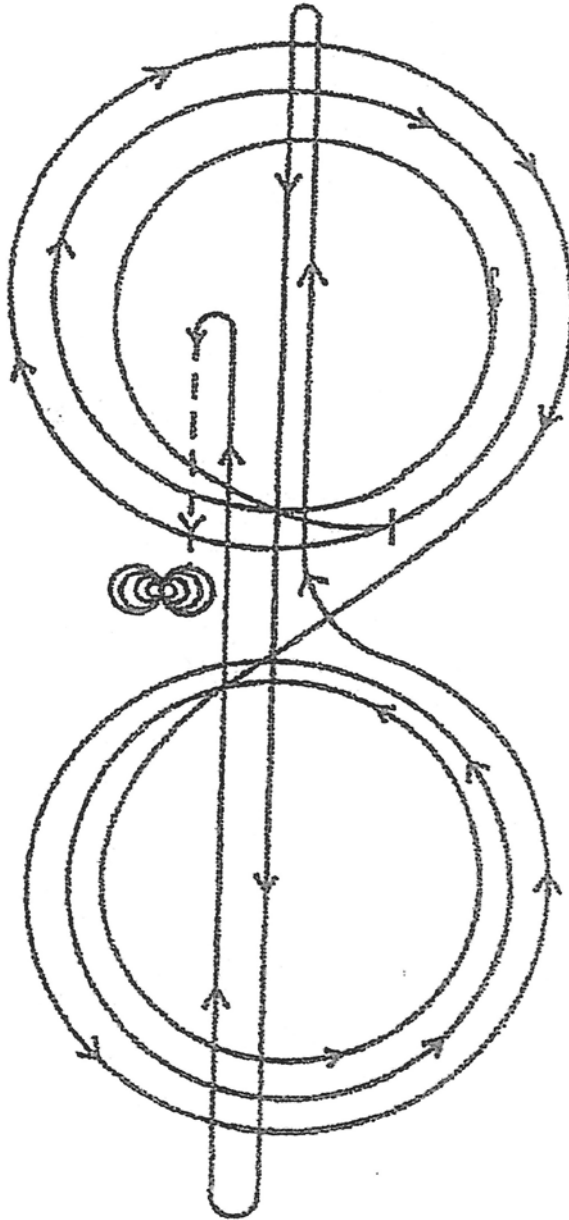

1. Beginning on the right lead, complete 3 circles to the right, the first circle small and slow, the next 2 circles large and fast. Change leads at the center of established pattern area.
2. Complete 3 circles to the left, the first circle small and slow, the next 2 circles large and fast. Change lead at center of established pattern area.
3. Run up the middle to the far end of the established pattern area past the marker and do a left roll back – no hesitation.
4. Run to the opposite end of the established pattern area past the end marker and do a right roll back – no hesitation.
5. Run past the center marker and do a sliding stop. Back up at least 10 feet. Hesitate.
6. Complete 4 spins to the right.
7. Complete 4 spins to the left. Hesitate to demonstrate the completion of the pattern.
8. Exhibitor may drop bridle to designated judge.

The arena should be approximately 50 feet by 150 feet. Markers should be placed on the fence or wall to indicate the length of the pattern.

REINING PATTERN NUMBER 7

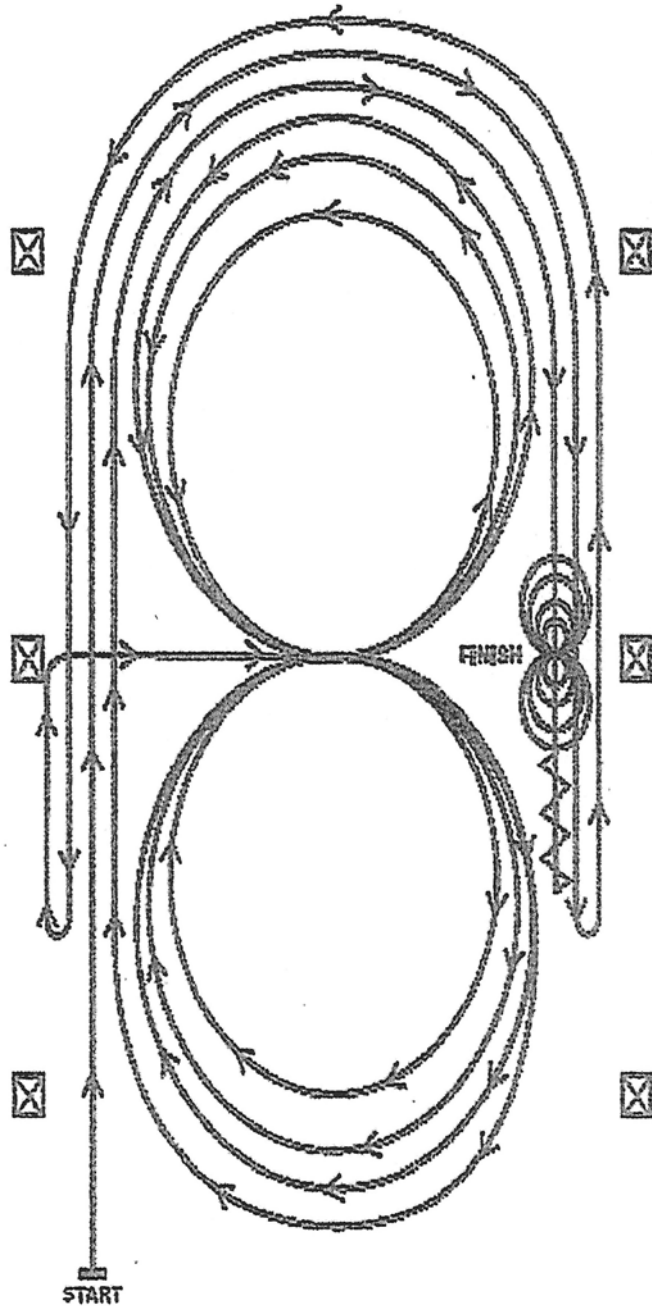

1. Beginning lope straight up the left side of the arena, circle the top end of the arena, and staying at least 20 feet (six meters) from the walls or fence, run straight down the opposite or right side of the arena past the center marker and do a left rollback – no hesitation.
2. Continue straight up the right side of the arena circle back around the top of the arena, and staying at least 20 feet (six meters) from the walls or fence, run straight down the left side of the arena past the center marker and do a right rollback – no hesitation.
3. Continue up the left side of the arena to the center marker. At the center marker, the horse should be on the right lead. Guide the horse to the center of the arena on the right lead and complete three circles to the right: the first two circles large and fast: the third circle small and slow. Change leads at the center of the arena.
4. Complete three circles to the left: the first two circles large and fast: the third circle small and slow. Change leads in the center of the arena.
5. Begin a large fast circle to the right but do not close this circle. Continue up the left side of the arena, circle the top of the arena, staying at least 20 feet (six meters) from the walls or fence, run straight down the opposite or right side of the arena past the center marker and do a sliding stop. Back up at least 10 feet (three meters). Hesitate.
6. Complete four spins to the right. Hesitate
7. Complete four spins to the left. Hesitate to demonstrate completion of the pattern.

Rider may drop bridle to the designated judge.

REINING PATTERN NUMBER 8

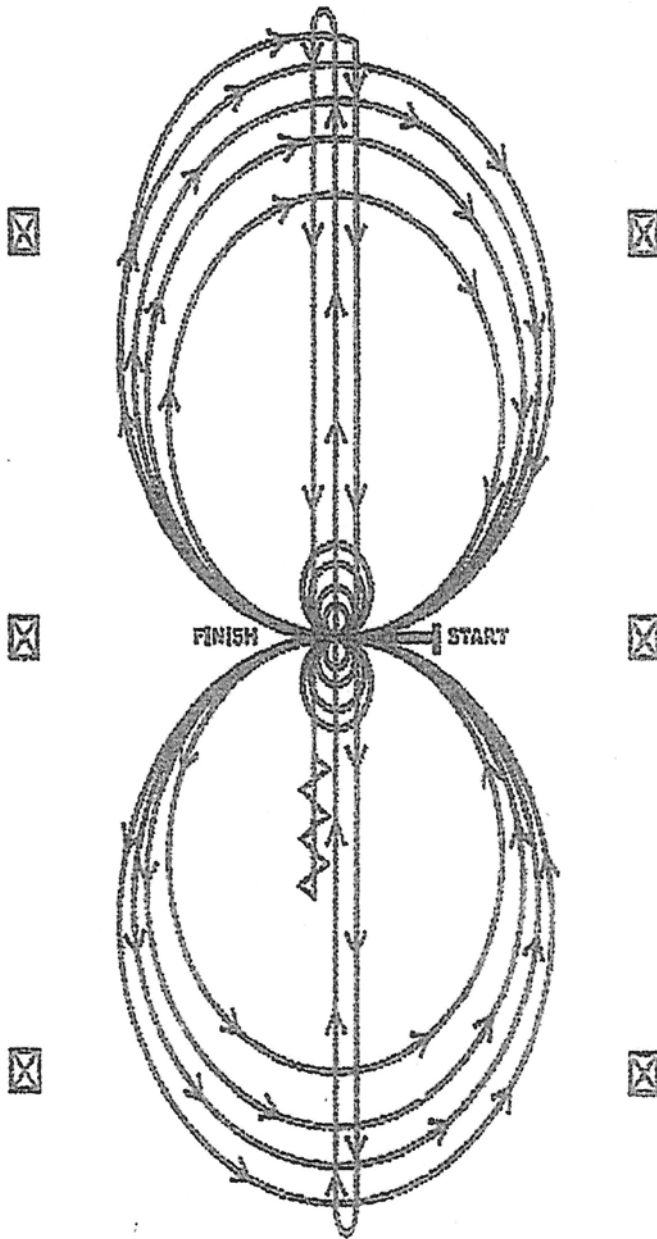

Horses may walk to the center of the arena. Horses must walk or stop prior to starting pattern, beginning at the center of the arena, facing the left wall or fence.

1. Beginning on the right lead, complete three circles to the right: the first two large and fast, the third circle small and slow. Stop at the center of the arena. Hesitate.
2. Complete four spins to the right. Hesitate.
3. Beginning on the left lead, complete three circles to the left: the first two circles large and fast: the third circle small and slow. Stop at the center of the arena. Hesitate.
4. Complete four spins to the left. Hesitate.
5. Beginning on the right lead, run a large, fast circle to the right, change leads at the center of the arena, run a large, fast circle to the left, and change leads at the center of the arena. (*Figure 8*)
6. Continue around previous circle to the right. At the top of the circle, run down the middle to the far end of the arena past the end marker and do a right rollback – no hesitation.
7. Run up the middle to the opposite end of the arena past the end marker and do a left rollback – no hesitation.
8. Run past the center marker and do a sliding stop. Back up to the center of the arena or at least 10 feet (three meters). Hesitate to demonstrate completion of the task.

Rider may drop bridle to the designated judge.

REINING PATTERN NUMBER 9

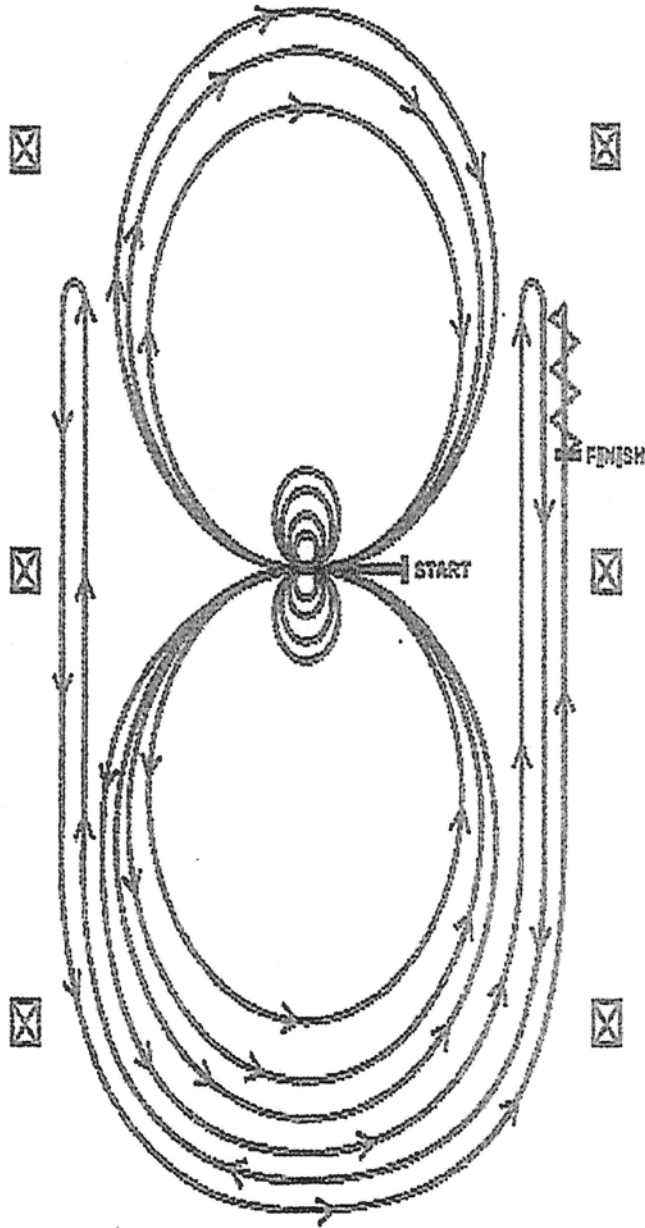

1. Complete four spins to the right. Hesitate.
2. Complete four spins to the left. Hesitate.
3. Beginning on the left lead, complete three circles to the left: the first two circles large and fast: the third circle small and slow. Change leads at the center of the arena.
4. Complete three circles to the right: the first two circles large and fast: the third small and slow. Change leads at the center of the arena.
5. Begin a large, fast circle to the left but do not close this circle. Run up the right side of the arena past the center marker and do a right rollback at least 20 feet (six meters) from the wall or fence – no hesitation.
6. Continue back around previous circle but do not close this circle. Run up the left side of the arena past the center marker and do a left rollback at least 20 feet (six meters) from the wall or fence – no hesitation.
7. Continue back around previous circle but do not close this circle. Run up the right side of the arena past the center marker and do a sliding stop at least 20 feet (six meters) from the wall or fence. Back up at least 10 feet (three meters). Hesitate to demonstrate the completion of the pattern.

Rider may drop bridle to the designated judge.

REINING PATTERN NUMBER 10

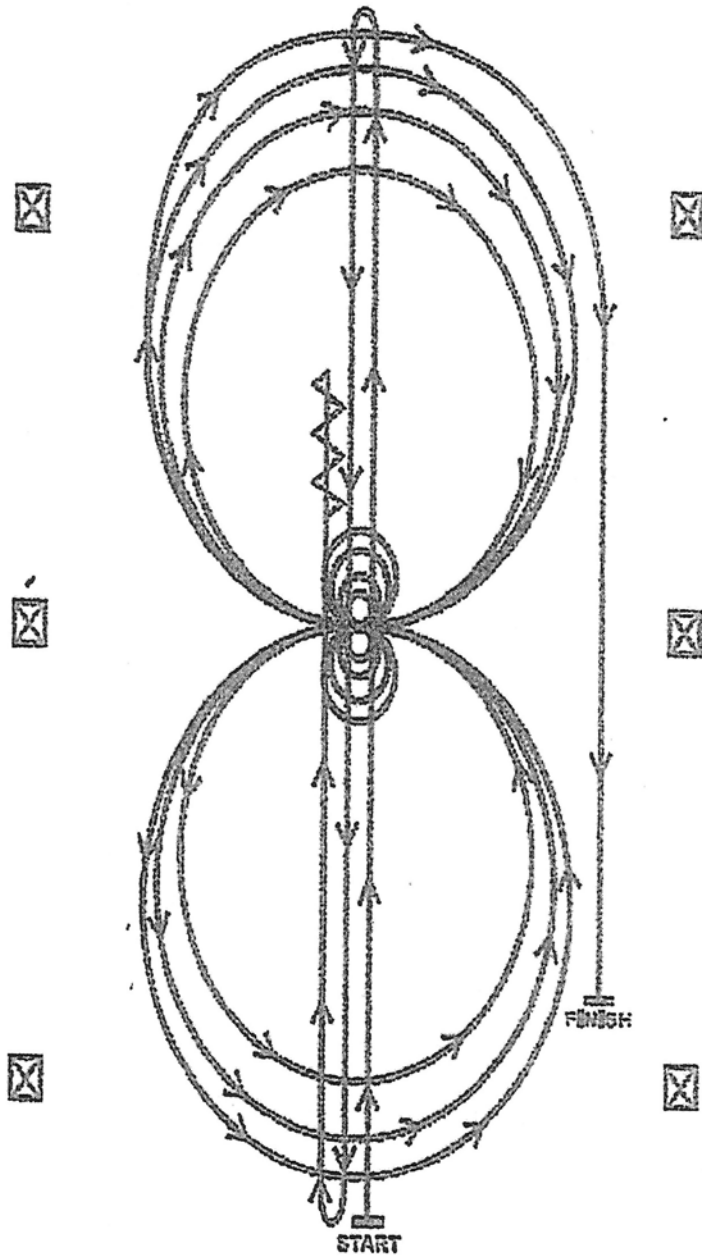

1. Run at speed to the far end of the arena past the end marker and do a left rollback – no hesitation.
2. Run to the opposite end of the arena past the end marker and do a right rollback – no hesitation.
3. Run past the center marker and do a sliding stop. Back up to the center of the arena or at least 10 feet (three meters). Hesitate.
4. Complete four spins to the right. Hesitate.
5. Complete four and one quarter spins to the left so that the horse is facing left wall or fence. Hesitate.
6. Beginning on the right lead, complete three circles to the right: the first two circles large and fast: the third circle small and slow. Change leads at the center of the arena.
7. Complete three circles to the left: the first two circles large and fast: the third circle small and slow. Change leads at the center of the arena.
8. Begin a large, fast circle to the right but do not close this circle. Run straight down the right side of the arena past the center marker and do a sliding stop at least 20 feet (six meters) from the wall or fence. Hesitate to demonstrate completion of the pattern.

Rider may drop bridle to the designated judge.

REINING PATTERN NUMBER 11

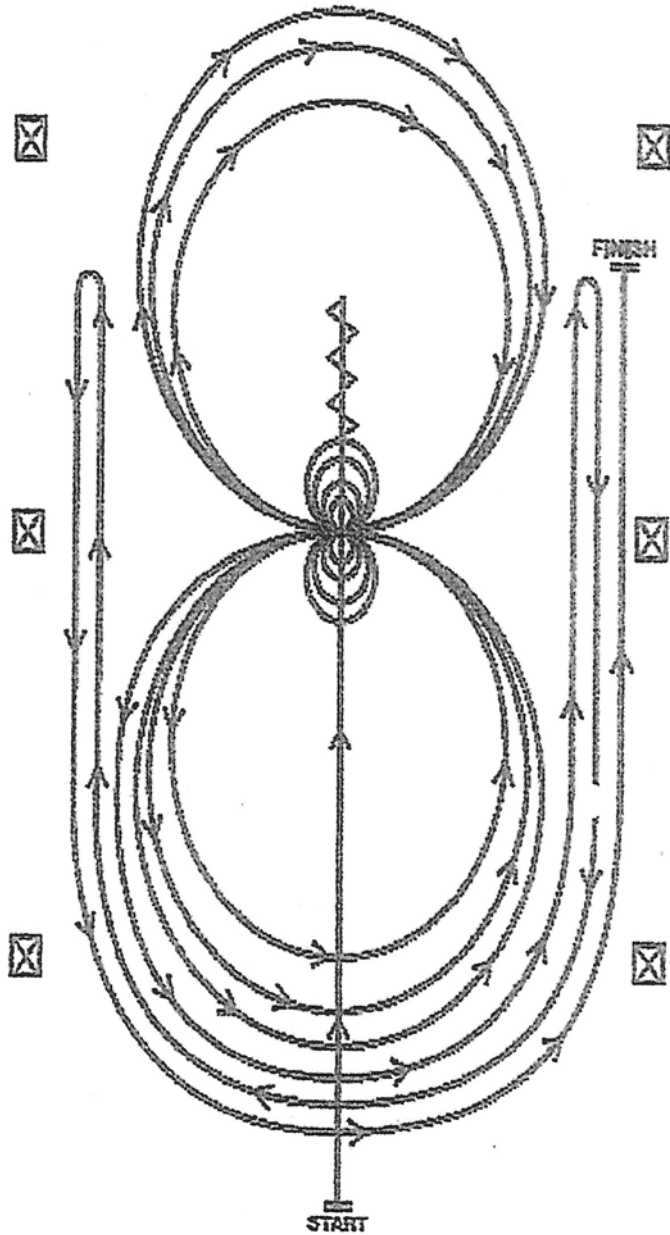

1. Run past the center marker and do a sliding stop. Back up to the center of the arena or at least 10 feet (three meters). Hesitate.
2. Complete four spins to the right. Hesitate.
3. Complete four and one-quarter spins to the left so that the horse is facing the left wall or fence. Hesitate.
4. Beginning on the left lead, complete three circles to the left: the first circle small and slow; the next two circles large and fast. Change leads at the center of the arena.
5. Complete three circles to the right: the first circle small and slow; the next two circles large and fast. Change leads at the center of the arena.
6. Begin a large, fast circle to the left but do not close this circle. Run up the right side of the arena past the center marker and do a right rollback at least 20 feet (six meters) from the wall or fence – no hesitation.
7. Continue back around the previous circle but do not close this circle. Run up the left side of the arena past the center marker and do a left rollback at least 20 feet (six meters) from the wall or fence – no hesitation.
8. Continue back around previous circle but do not close this circle. Run up right side of the arena past the center marker and do a sliding stop at least 20 feet (six meters) from the wall or fence. Hesitate to demonstrate completion of the pattern.

Rider may drop bridle to the designated judge.

REINING PATTERN NUMBER 12

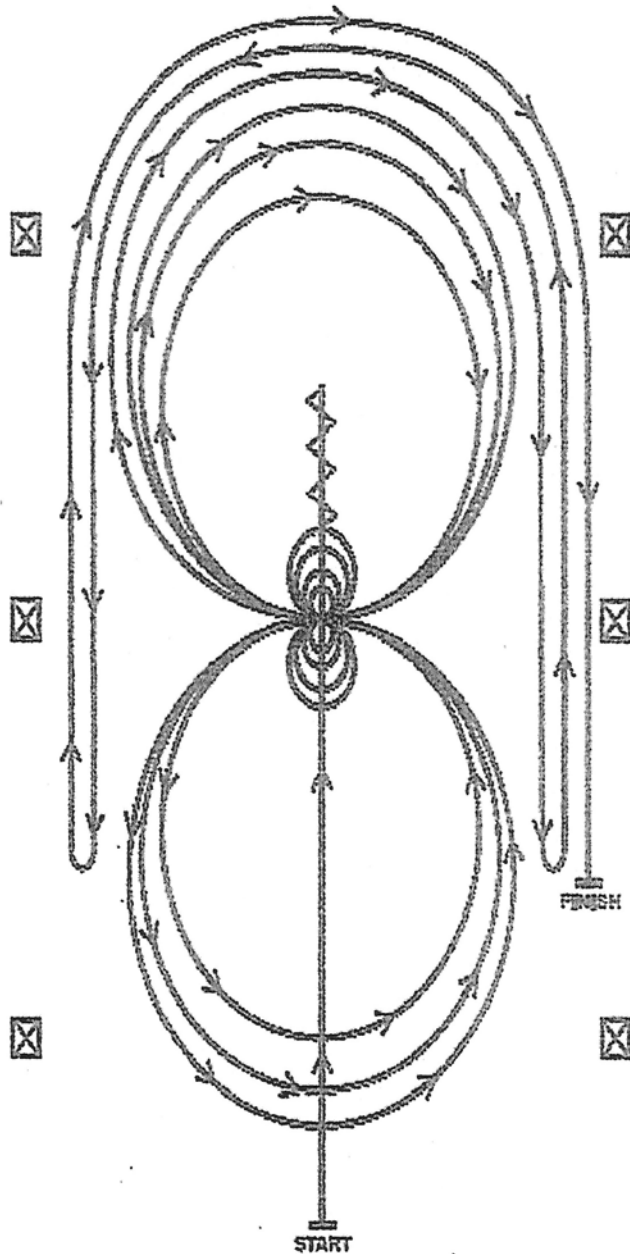

1. Run past the center marker and do a sliding stop. Back up to the center of the arena or at least 10 feet (three meters). Hesitate.
2. Complete four spins to the right. Hesitate.
3. Complete four and one-quarter spins to the left so that the horse is facing the left wall or fence. Hesitate.
4. Beginning on the right lead, complete three circles to the right: the first two circles large and fast.; the third circle small and slow. Change leads at the center of the arena.
5. Complete three circles to the left: the first circle small and slow: the next two circles large and fast. Change leads at the center of the arena.
6. Begin a large, fast circle to the right but do not close this circle. Run down the right side of the arena past the center marker and do a left rollback at least 20 feet (six meters) from the wall or fence – no hesitation.
7. Continue back around the previous circle but do not close this circle. Run down the left side of the arena past the center marker and do a right rollback at least 20 feet (six meters) from the wall or fence – no hesitation.
8. Continue back around previous circle but do not close this circle. Run down the right side of the arena past the center marker and do a sliding stop at least 20 feet (six meters) from the wall or fence. Hesitate to demonstrate completion of the pattern.

Rider may drop bridle to the designated judge.

REINING PATTERN NUMBER 13

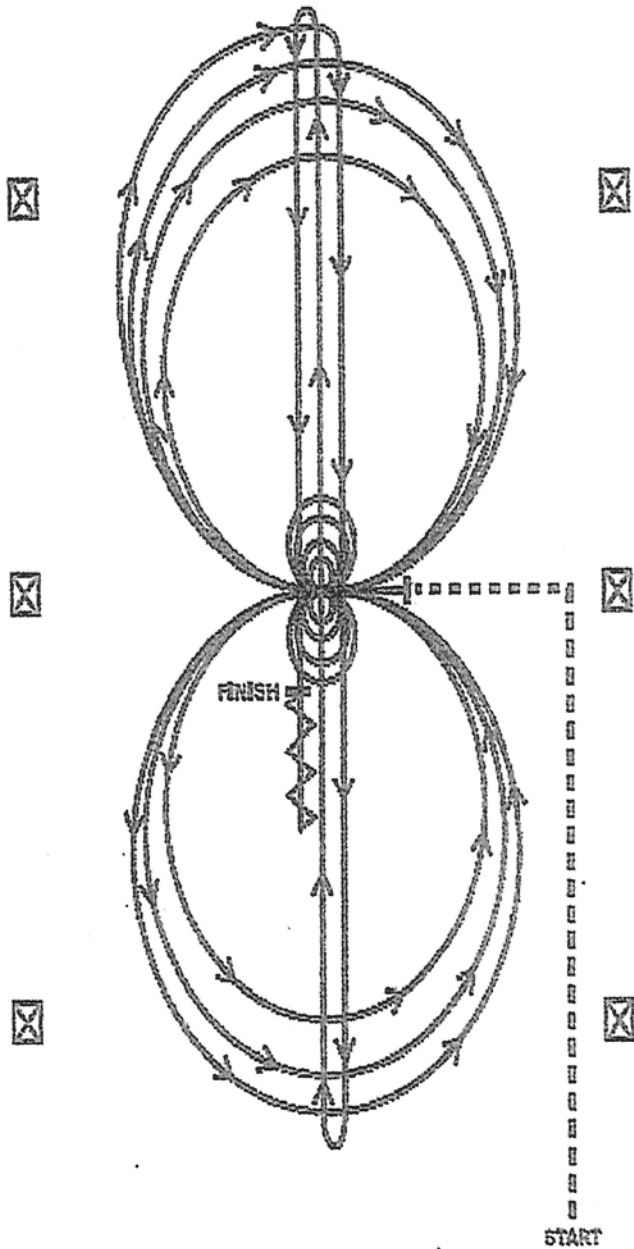

Horses may walk or flat walk to the center of the arena. Horse must walk or stop prior to starting the pattern. Beginning at the center of the arena facing the left wall or fence.

1. Complete four spins to the left. Hesitate.
2. Complete four spins to the right. Hesitate.
3. Beginning on the right lead complete three circles to the right: the first circle small and slow: the next two circles large and fast. Change leads at the center of the arena.
4. Complete three circles to the left: the first circle small and slow: the next two circles large and fast. Change leads at the center of the arena.
5. Begin a large circle to the right but do not close this circle. Run down the center of the arena past the end marker and do a right rollback – no hesitation.
6. Run up the middle to the opposite end of the arena past the end marker and do a left rollback – no hesitation.
7. Run past the center marker and do a sliding stop. Back up to the center of the arena or at least 10 feet (three meters). Hesitate to demonstrate completion of the pattern.

Rider may drop bridle to the designated judge.

SHOWMANSHIP DIVISION

Showmanship at Halter

Available only in the amateur and youth divisions.

- 1. CLASS DESCRIPTION:** The showmanship class shall be designed to evaluate the exhibitor's ability to execute, in concert with a well groomed and conditioned horse, a set of maneuvers prescribed by the judge with precision and smoothness while exhibiting poise and confidence, and maintaining a balanced, functional and fundamentally correct body position.

It is mandatory that the judge post any pattern(s) to be worked at least one hour prior to the commencement of the class. Pattern(s) should be designed to test the exhibitor's ability to effectively present a horse to the judge. All ties will be broken at the judges' discretion.

- 2. CLASS PROCEDURES:** All exhibitors may enter the ring and then work individually or each exhibitor may be worked from the gate individually. When exhibitors are worked individually from the gate, a working order may be required. The following maneuvers are considered acceptable: lead the horse at a walk, running walk or intermediate gait, or back in a straight or curved line, or a combination of straight and curved lines; stop; and turn 90 (1/4), 180 (1/2), 270 (3/4), 360 (full turn) degrees or any combination or multiple of these turns. The judge must have exhibitors set the horse up squarely for inspection sometime during the class.
- 3. PRESENTATION AND POSITION OF EXHIBITOR:** Clothes and person are to be neat and clean. Exhibitors may show in either English or Western attire and appointments, but never a combination of both. Exhibitors should be poised, confident, courteous and genuinely sportsmanlike at all times, quickly recognizing and correcting faults in the positioning of the horse. The exhibitor should continue showing the horse until the class has been placed or they have been excused, unless otherwise instructed by the judge. The exhibitor should appear business-like, stand and move in a straight, natural and upright manner, and avoid excessive, unnatural or animated body positions.

The exhibitor must lead on the horse's left side holding the lead shank in the right hand near the halter with the bight of the lead neatly coiled in the left hand. It is preferable that the exhibitor's hand not be on the snap or chain portion of the lead, and to

do so should be penalized. When leading, the exhibitor should be positioned between the eye and the mid-point of the horse's neck, referred to as the leading position.

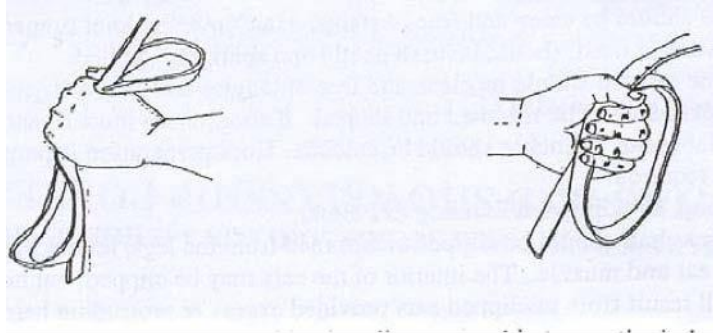

Both arms should be bent at the elbow with the elbows held close to the exhibitors' side and the forearms held in a natural position. Height of the arms may vary depending on the size of the horse and exhibitor, but the arms should never be held straight out with the elbows locked. The position of the exhibitor when executing a turn to the right is the same as the leading position except that the exhibitor should turn and face toward the horse's head and have the horse move away from them to the right.

When executing a back, the exhibitor should turn from the leading position to face toward the rear of the horse with the right hand extended in front of the exhibitor's chest still maintaining slight bend in the elbow and walk forward. Ideally, the exhibitors' left shoulder to be in alignment with the horses' left front leg.

When setting the horse up for inspection, the exhibitor should stand angled toward the horse in a position between the horses' eye and muzzle, and should never leave the head of the horse. The exhibitor must use the Quarter Method (see diagram) when presenting the horse. The exhibitor should maintain a position that is safe for themselves and the judge. The position of the exhibitor should not obstruct the judge's view of the horse and should allow the exhibitor to maintain awareness of the judge's position at all times. The exhibitor should not crowd other exhibitors when setting up side-by-side or head-to- tail. When moving around the horse, the

exhibitor should change sides in front of the horse with minimal steps and should assume the same position on the right side of the horse that they had on the left side. Leading, backing, turning and initiating the set-up should be performed from the left side of the horse. At no time should the exhibitor ever stand directly in front of the horse. The exhibitor should not touch the horse with their hands or feet, or visibly cue the horse. Whips are prohibited.

Judge is in	Exhibitor should be in
1	4
2	1
3	4
4	1

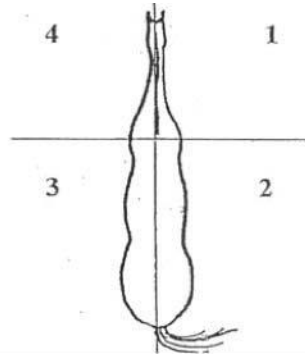

4. **PRESENTATION OF THE HORSE:** The horses' body condition and overall fitness should be assessed. Horses may be presented in either English or Western tack, depending on the attire of the exhibitor, but never a combination of both. **Must be shown in well fitted halter.** When exhibiting in a halter, a chain shank may be used in a humane manner, but never through the mouth. The hair coat should be clean, well brushed and in good condition. The mane, tail, forelock and wither tuft must be well conditioned and groomed. The length of mane and tail may vary, as long as they are neat, clean and free of tangles. The bridle path, eyebrows, and long hair on the head and legs may be clipped, except where government regulations prohibit. The hooves should be properly trimmed and if shod, the shoes should fit correctly and clinches should be neat. Hooves must be clean and may be with hoof dressings, or shown naturally. All tack should fit properly and be neat, clean and in good repair. Horses shown under English tack should be braided with ribbons as is customary for that discipline, while horses shown under Western tack should show as tradition allows.

5. **PERFORMANCE:** The exhibitor should perform the work accurately, precisely, smoothly, and with a reasonable amount of speed. Increasing speed of the work increases the degree of difficulty, however, accuracy and precision should not be sacrificed for speed. The horse should lead, stop, back, turn and set up willingly, briskly and readily with minimal visible or audible cueing. A severe disobedience will not result in a disqualification but should be penalized appropriately, and the exhibitor should not place above an exhibitor that completes the pattern correctly. Excessive schooling or training, willful abuse, loss of control of the horse by the exhibitor, failure to follow prescribed pattern, knocking over or working on the wrong side of the

cones shall be cause for disqualification.

The horse should be led directly to and away from the judge in a straight or curved line and track briskly and freely at the prescribed gait as dictated by the pattern. The horse's head and neck should be straight and in line with the body. All halts should be straight, prompt, smooth and responsive with the horse's body remaining straight. The horse should back readily with the head, neck and body aligned in a straight or curved line as instructed. Pull turns to the left should be 90 degrees or less. For turns of greater than 90 degrees, the ideal turn consists of the horse pivoting on the right hind leg while stepping across and in front of the right front leg with the left front leg. An exhibitor should not be penalized if their horse performs a pivot on the left hind leg, but an exhibitor whose horse performs the pivot correctly should receive more credit.

The horse should be set up quickly with the feet squarely underneath the body. The exhibitor does not have to reset a horse that stops square.

When posed, the Western horse (stock type) should stand square, with all four legs squarely under the body. The English horse should stand with feet slightly spread and head up, but never over-stretched.

6. SCORING:

Exhibitors are to be scored from 0 to 100 with 70 denoting an average performance. Whole and half point increments are acceptable. Run content scores will be indicated as follows:

Overall Condition of Horse	15 points
Grooming of Horse	20 points
Exhibitor	15 points
Leading	15 points
Posing for Inspection	15 points
Pattern Execution	20 points

+ = Above Average

✓ = Average

= Below Average

An additional + (Excellent) or – (well below average) may be given.

Overall Presentation of Exhibitor and Horse: *The exhibitor's overall poise, confidence, appearance and position throughout the class, and the physical appearance of the horse will be evaluated.*

Faults: *Faults can be classified as minor, major or severe. The judge will determine the appropriate classification of a fault based*

upon the degree and/or frequency of the infraction.

a. Minor faults

Break of gait at walk, running walk, or intermediate gait for 1 stride Sliding a pivot foot or lifting foot and replacing in same place.

b. Major faults

Not performing gait or not stopping within 5 feet of designated area
Break of gait at walk, running walk, or intermediate gait for more than one stride Splitting the cone.

Picking up a pivot foot
Picking up a foot after presentation
Over/under turning 1/8 to 1/4 of designated turn

c. Severe Faults (avoids disqualification but should be placed below other exhibitors that do not incur a severe fault) include:

Out of position during presentation
Exhibitor touching the horse or kicking or pointing their feet at the horse's feet during set up
Standing directly in front of the horse
Loss of lead shank or holding chain or two hands on shank.
Severe disobedience including rearing or pawing;
horse kicking at other horses, exhibitors or judge
Horse continuously circling the exhibitor

d. Disqualifications (should not be placed) include:

Loss of control of horse that endangers exhibitor, other horses or exhibitors The horse escaping from the exhibitor
Failure of exhibitor to wear correct number in a visible manner Willful abuse
Excessive schooling or training, or use of artificial aids Knocking over the cone or going off pattern
Never performing specific gait
Over turning more than 1/4 turn of designated turn

7. SUGGESTED FINAL SCORING: Final scoring shall be on a basis of 0–100, with an approximate breakdown as follows:

90-100 Excellent showmanship, including body position and presentation of horse. Completes pattern accurately, quickly, smoothly and precisely; demonstrates a high level of professionalism.

80-89 Above average performance in execution of the pattern as well as correct showmanship and presentation of horse. Excellent showman that commits a minor fault.

70-79 Average pattern execution and average showmanship; lacking adequate style and professional presentation to merit elevating to the next scoring range. Above average showman that commits a minor fault.

60-69 Below average pattern that lacks quickness or precision. Horse with consistently unwilling attitude or handler with obvious position and/or presentation faults that prevents effective showmanship. An average showman that commits two minor faults in the performance of the pattern. An excellent showman that commits a major fault.

50-59 One major fault or multiple minor faults in the performance or presentation or position of exhibitor that precludes effective communication with the horse.

40-49 Severe fault, two or more major faults, or multiple minor faults in the performance or the execution of the pattern and demonstrates a lack of handling ability and knowledge of correct body position.

10-39 Exhibitor commits more than one severe fault or multiple major faults in performance or position but completes the class and avoids disqualification.

SAMPLE PATTERNS

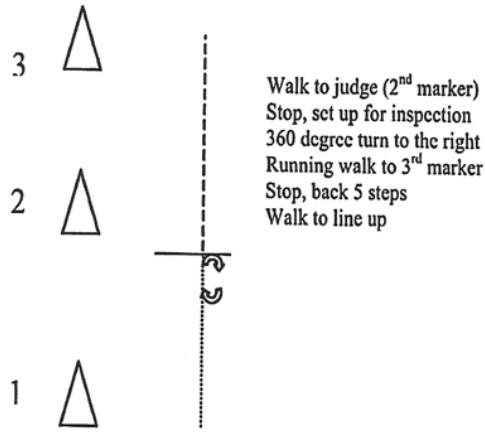

Walk to judge (2nd marker)
 Stop, set up for inspection
 360 degree turn to the right
 Running walk to 3rd marker
 Stop, back 5 steps
 Walk to line up

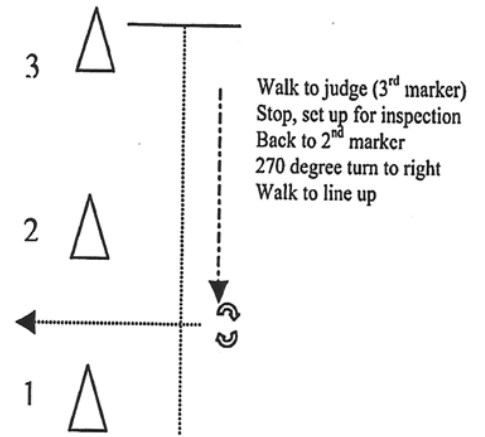

Walk to judge (3rd marker)
 Stop, set up for inspection
 Back to 2nd marker
 270 degree turn to right
 Walk to line up

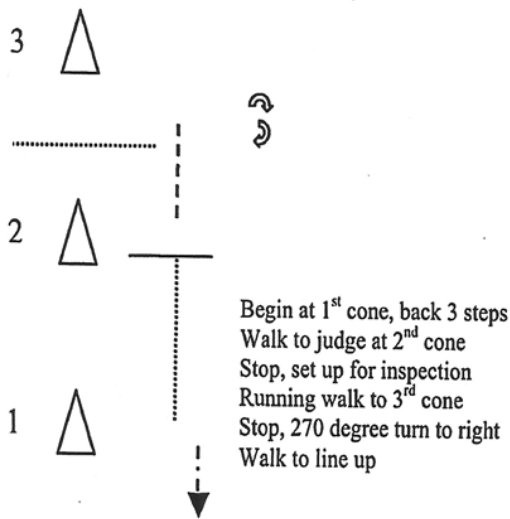

Begin at 1st cone, back 3 steps
 Walk to judge at 2nd cone
 Stop, set up for inspection
 Running walk to 3rd cone
 Stop, 270 degree turn to right
 Walk to line up

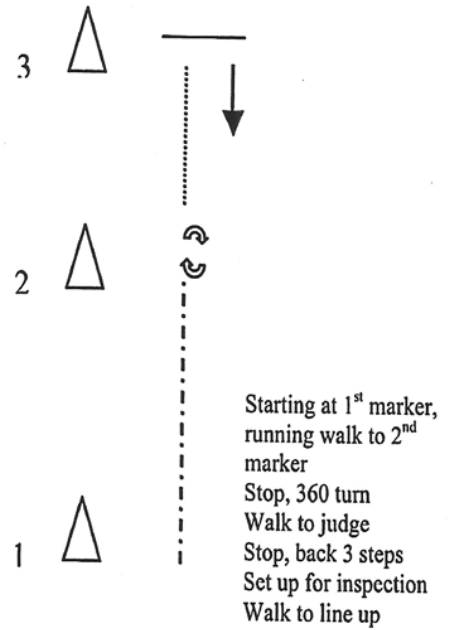

Starting at 1st marker,
 running walk to 2nd
 marker
 Stop, 360 turn
 Walk to judge
 Stop, back 3 steps
 Set up for inspection
 Walk to line up

TIMED EVENTS/CONTEST CLASSES

For tack and attire, see equipment chart.

General Rules

- In all timed events, Western tack and attire, as described in equipment chart, are required. Helmets are suggested.
- Quick change bridles and reins are allowed in Time Events
- The hat or helmet must be on the rider's head when the contestant enters the arena. A 5 second penalty will be incurred if the hat or helmet is not on the contestant's person for the entire time the contestant is in the arena. (Hats may be held on the body by a stampede string.)
- Use of hackamore or other type of bridle is the option of the contestant; however, the judge may prohibit the use of bits or equipment that he may consider severe.
- Whips, crops, or bats of any kind are prohibited.
- Gate must be closed during contestant's run.
- All contestants must enter the gate in a safe, controlled manner.
- Scores are based on the time incurred in running the proper pattern from the start line to the finish line. Penalties will be added to the final time. A run-off will be held in case of a tie, with the loser taking the next lower placing than the winner. In case both contestants in a run-off are disqualified, both contestants will continue to re-run until a winner can be determined. The horse declared the winner in the run-off must re-run the pattern within 2 seconds of its original time or the run-off must be held again.
- An electric timer or two stopwatches will be used. If watches are used, the official time will be the average time of the watches used by officials. Time begins when horse's nose passes starting line and ends when horse's nose passes finish line.

Re-rides will be granted for

- Timer malfunction
- Tack failure that affects control or safety
- At the discretion of the judge, any event beyond the control of the contestant that adversely affects the performance of the horse

Disqualification:

- Off course
- Fall of horse or rider
- Use of prohibited items of tack or appointments
- Unsportsmanlike conduct, including but not limited to the use of profanity, disorderly conduct or excessive jerking, spurring, spinning, slapping or backing of the horse.
- Re-crossing start/finish line before completing the course
- Any rule calling for disqualification as stated in event specific rules.

CLOVERLEAF BARRELS

Course:

- 3 barrels are placed in a triangle formation spaced as closely as possible to the course drawn below.
- If the course is too large for the available space, the pattern should be reduced 5 yards at a time until the pattern fits the arena. The distance from barrel number #3 to the finish line need not be reduced 5 yards at a time if there is sufficient room for the horse to stop.
- It is recommended that there be at least 45 feet from the starting line to the end of the arena and 36 feet from barrel 3 to the end of the arena. Barrels must be at least 18 feet from arena fence.
- Clearly visible starting line markers should be placed against the fence.

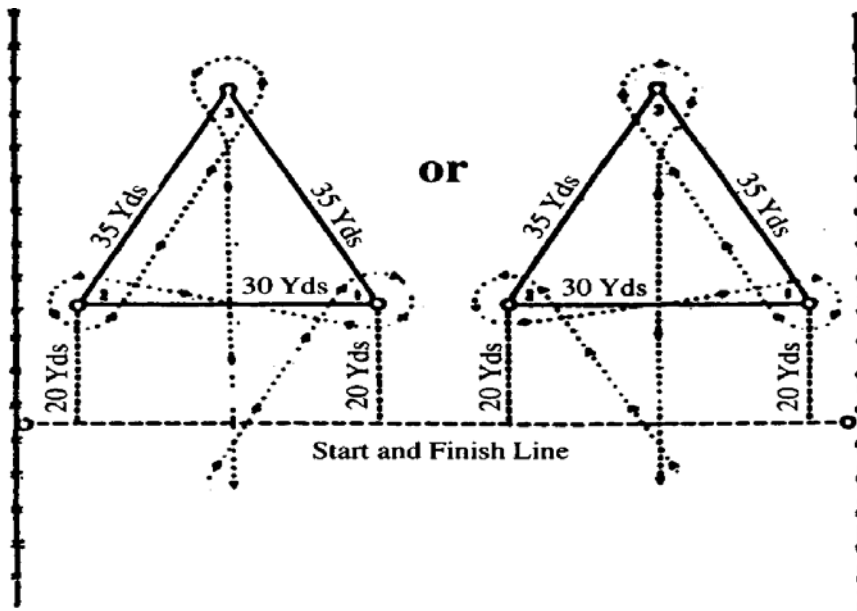

Event

Contestant runs to barrel #1, passing to left of the barrel and completing an approximately 360 degree turn around it. Contestant continues to barrel #2, passing to the right of it, completing a slightly more than 360 degree turn around it, then goes to barrel #3, passing to the right of it and completing an approximately 360 degree turn around it, then sprinting to the finish line passing between barrels #1 and #2. The course may be run either to the left or right as shown above.

Penalties

In addition to penalties and disqualifications stated in the general rules for all timed events, the following are specific to barrel racing:

- Knocking over a barrel: 5 second penalty per barrel. A contestant may touch the barrel with his or her hand.
- Striking the horse in front of the cinch with anything other than a open hand: 5 second penalty.

STRAIGHT LINE BARRELS

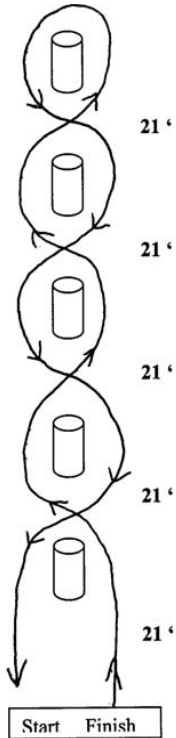

Course

- 5 barrels placed in a straight line, spaced 21 feet apart, with the first barrel 21 feet from the start/finish line.
- Clearly visible starting line markers should be placed against the fence.

Event

Contestant rides to first barrel from either side, weaves in and out to barrel 5, turns barrel 5 and weaves back toward finish line, ending on opposite side of barrel 1 before crossing finish line

Penalties

In addition to penalties and disqualifications stated in the general rules for all timed events, the following are specific to quadrangle barrels:

- Knocking over a barrel: 5 second penalty per barrel. A contestant may touch the barrel with his or her hand.
- Striking the horse in front of the cinch with anything other than an open hand: 5 second penalty.

TEXAS T BARRELS

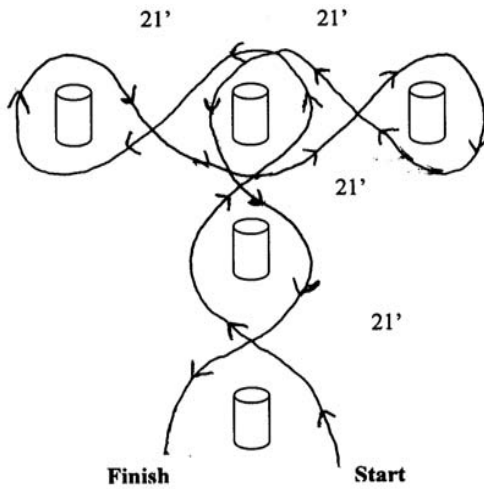

Course

- 5 barrels placed in a “t” formation as shown
- All barrels are 21 feet apart and from start/finish line
- Barrels must be at least 18 feet from arena fence
- Clearly visible starting line markers should be placed against the fence.

Event

Rider may approach the first barrel from either side and round remaining barrels on alternate sides as shown in diagram.

Penalties

In addition to penalties and disqualifications stated in the general rules for all timed events, the following are specific to Texas T barrels:

- Knocking over a barrel or pylon: 5 second penalty per barrel. A contestant may touch the barrel with his or her hand.
- Striking the horse in front of the cinch with anything other than a open hand: 5 second penalty.

POLE BENDING

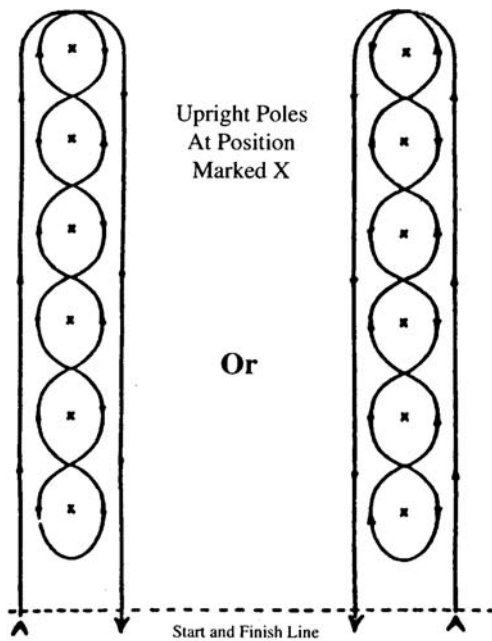

Course

- 6 poles placed in a straight line, spaced 21 feet apart, with the first pole placed 21 feet from the start/finish line.
- Poles are set on top of the ground, 6 feet in height with bases no more than 14 inches in diameter.
- Clearly visible starting line markers should be placed against the fence.

Event

Contestant rides to pole #6, on either side, turns pole #6 left or right, then weaves around the opposite side of each pole to pole #1. Turn pole #1 and weave around the opposite side of each pole to pole #6, turn pole #6 and ride to finish line on the opposite side of the poles from the initial run in.

Penalties

In addition to penalties and disqualifications stated in the general rules for all timed events, the following are specific to pole bending:

- Knocking over a pole: 5 second penalty per pole.
- Touching the pole with the rider's hand: 5 second penalty
- Striking the horse in front of the cinch with anything other than an open hand: 5 second penalty.

KEYHOLE RACE

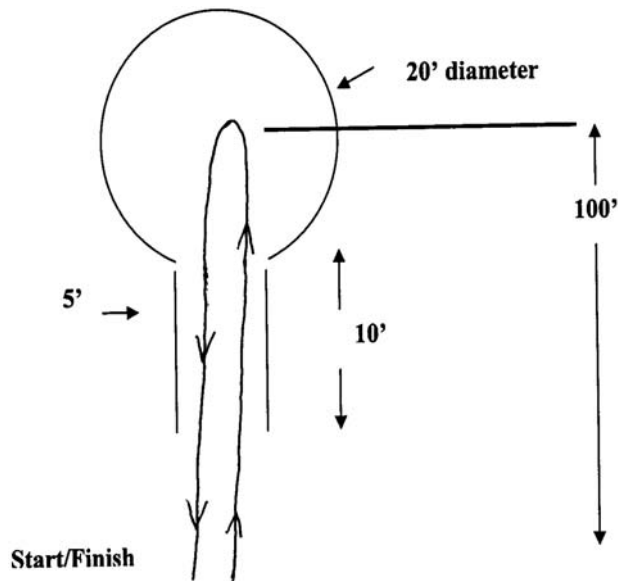

Course

- Keyhole pattern is outlined and marked with line marker or flour as shown.
- Circle must be 20 feet in diameter
- Keyhole “slot” should be 5 feet wide and 10 feet long
- Recommended distance from start/finish line to center of keyhole is 100 feet
- Starting line must be clearly visible.

Event

Contestant rides through slot into circle of keyhole, rolls back either left or right, rides out of keyhole and across the finish line. All 4 feet of the horse must be inside the circle during the turn.

Penalties

In addition to penalties and disqualifications stated in the general rules for all timed events, the following are specific to keyhole race:

- Stepping on or outside any of the marked lines of the keyhole
- Failure of the horse to have all 4 feet inside the circle before the turn will result in disqualification.
- Striking the horse in front of the cinch with anything other than an open hand: 5 second penalty. Note: In addition to timer and official judge, watchers must be stationed on either side of keyhole to observe the feet of the horse and re-mark lines which may be broken or obliterated.

STAKE RACE

Course

- 2 poles placed in a straight line. Poles are each 40 feet from the start/finish line, making them 80 feet apart.
- Start and finish line is 20 feet wide and marked by 2 upright markers 10 feet on each side of the centerline and short enough not to interfere with the timer. (Cones or short pylons are recommended)

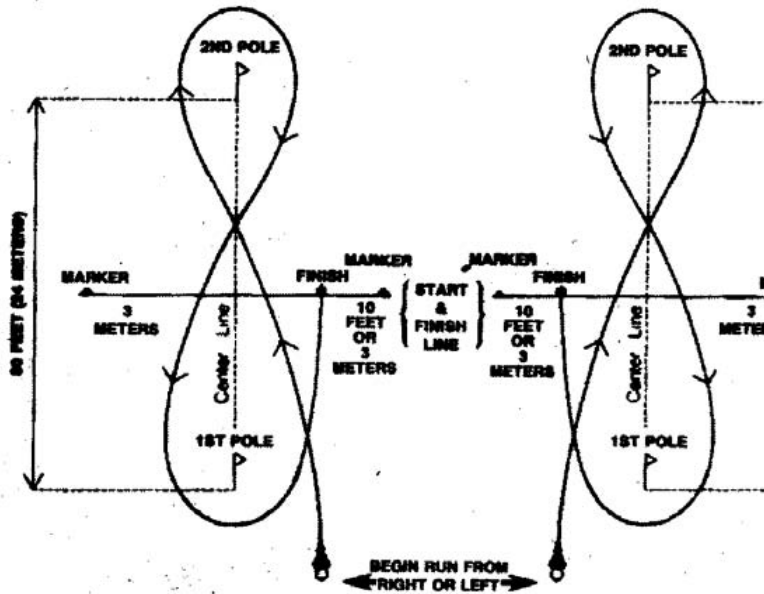

Event

Contestant may begin his run from either the left or right of the first pole. Start by crossing the center line between the upright markers, turn around the second pole, cross the center line again between the markers, then around the first pole and run back across finish line.

Penalties

In addition to penalties and disqualifications stated in the general rules for all timed events, the following disqualifications are specific to stake race:

- Failure of contestant to cross the start and finish line between the markers
- Knocking down a marker or pole
- Failure of contestant to cross over the center line between the markers before turning the second pole and after turning the second pole
- Striking the horse in front of the cinch with anything other than an open hand incurs a 5 second penalty.

Note: Two courses may be provided side by side and contestants may compete against each other as well as the timer, if desired.

ONE BARREL SPEED

Course

- One barrel set up 180 feet from start line and at least 20 feet from arena fence. Event

Rider may run pattern on either side of the barrel, must circle the barrel and then cross the finish line. Penalties

In addition to penalties and disqualifications stated in the general rules for all timed events, the following are specific to one barrel speed:

- Knocking over the barrel results in disqualification.
- Striking the horse in front of the cinch with anything other than a open hand incurs a 5 second penalty.

ARENA FLAG RACE

Course

- 3 barrels set at least 20 feet from the rail.
- Barrel 1 and Barrel 3 must be 20 feet from the start/finish line Barrel 2 must be 130 feet from the start/finish line.

Containers for the flags shall be at least the size of a two-gallon bucket (plastic or rubber). Material in container (to about 1" from top) should be suitable material to allow flag to be easily removed and stuck, i.e., soybeans, corn, wheat, loose sand.

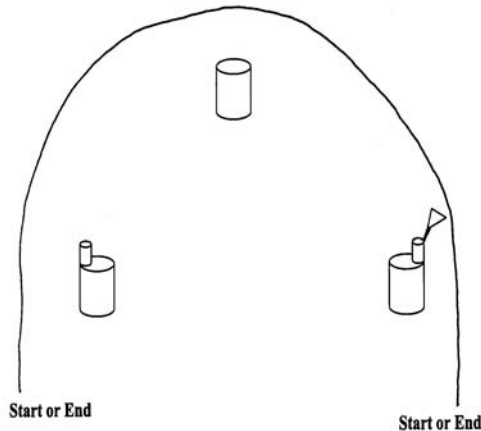

- Flagsticks should be 18" in length with about 1/2" round dowel and blunt ends.
- The container must be set on the outer edge of the barrel and the flag in the outer edge of the container.
- All contestants in a class will use the same flags. If a flag breaks during the run, the rider will be given a rerun.

Event

Contestants go on the outside of the first barrel, remove flag from bucket, ride on the outside of the second barrel, and ride on the outside of the third barrel to replace flag in bucket. Rider may run the course to the right or left. The rider must signal to the ring crew if they will be running right or left.

Penalties

In addition to penalties and disqualifications stated in the general rules for all timed events, the following disqualifications are specific to arena flag race:

- Failure to run the pattern
- Failure to obtain or replace flag
- Dropping the flag
- Knocking over any barrel
- Hitting the horse with the flag
- Striking the horse in front of the cinch with anything other than an open hand incurs a 5 second penalty.

HANDY HORSE

Course

- 1 barrel set up according to diagram below and a marked square at least 20 feet by 20 feet.
- Barrel and square must be at least 18 feet

from arena fence Event

Contestant runs from the starting line around both barrels into lined square.

When all 4 feet of the horse are in the square, the timer starts timing. When 5 seconds have elapsed, timer gives an audible signal and contestant exits the box and races across the finish line. Contestant must stop in square and stay there five

(5) seconds and then cross finish line. The judge shall signify to the ring steward when contestant has all 4 hooves in the square. The ring steward shall start timing when he receives the signal from the judge and give an audible signal to go when 5 seconds have elapsed.

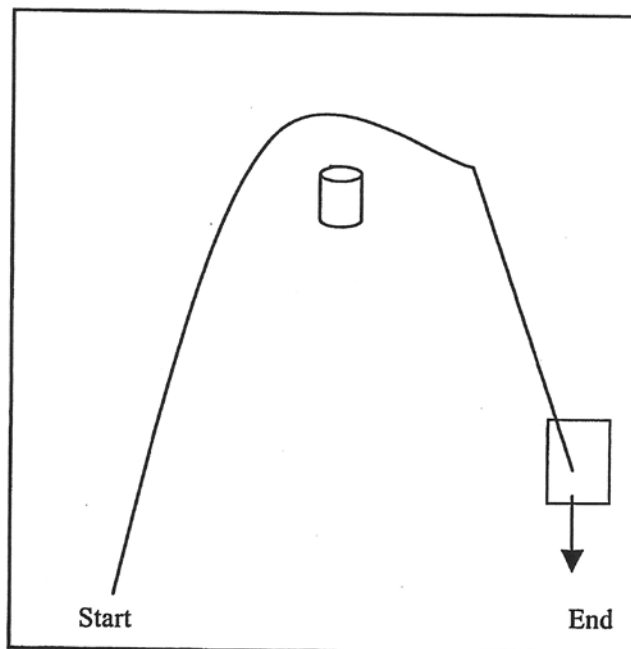

Penalties

- Striking the horse in front of the cinch with anything other than an open hand incurs a 5 second penalty.
- Knocking over a barrel incurs a 5 second penalty per barrel

CATALOG RACE

Course

- 1 barrel at the end of the arena with a closed catalog placed on top
- Starting line is placed at least 20 feet from arena gate and barrel must be at least 20 feet from arena fence

Event

Before contestant begins his run, the announcer calls out a page number. Contestant runs to barrel, dismounts, tears out the correct page, remounts, circles to the outside of the barrel and returns to the start/finish line.

Penalties

In addition to penalties and disqualifications stated in the general rules for all timed events, the following are specific to catalog race:

- Incorrect page
- Failure to circle barrel
- Knocking over the barrel
- Striking the horse in front of the cinch with anything other than an open hand incurs a 5 second penalty.

TIMED DRIVING GAMES

Tack and attire is the same as in other driving classes.

General rules

- Contestant's number must be clearly visible on his or her back.
- Events will be timed on individual runs; placing will be placed on fastest times.
- Contestants must enter and leave the arena at a walk or slow flat walk.
- Horse must be under control of driver at all times.
- Driver must start course within one (1) minute of being given the starting signal.
- In case of a tie, the drivers may flip a coin or accept a drive-off.
- In the event of a clock failure or interference, a contestant with a clean ride (no disqualifications) will be given a re-run. All re-drives will be made after the last driver in the class has completed the course.
- Only contestants, ring crew, and officials are allowed in the arena.
- During the running of any event, all arena gates must be closed.
- In all events, two (2) poles or cones thirty (30) feet apart shall designate the start–finish line. A horse and cart must pass between these poles at the start and finish or be considered off course.
- Markers may be poles, barrels, or traffic cones. All markers must be at least 12 inches high.
- In all events, the ring crew will reset downed equipment only after the competitor has completed the course.

Penalties

There shall be a five- (5) second penalty assessed for each of the following:

- Knockdown of a marker.
- Break from a running walk

Disqualifications

- Off course—failure to complete the course as diagrammed.
- Refusals.
- Upsetting the start-finish poles.
- Stopping the clock before completion of course by any portion of horse or cart.
- Failure to start within one (1) minute of the starting signal.
- A horse termed out of control or unmanageable by a judge.
- Upset of vehicle (if side of vehicle touches ground).

DRIVING BARREL RACE

Course: Three (3) markers placed in triangular formation 75 feet apart with first and second markers placed 30 feet out from the start–finish line. (Alternate course for narrow arena: first and second markers 33 feet out from start-finish line and 60 feet apart; third marker 30 feet from first and second markers.)

Pattern: Course may be driven to the right or to the left.

- *Right:* Driver crosses start–finish line, circles #1 marker to right, crosses to #2 marker, circles it to left, drives to #3 marker, circles it to left and returns across start–finish line.
- *Left:* Driver crosses start-finish line, circles #2 marker to left, crosses to #1 marker, circles it to right, drives to #3 marker, circles it to right and returns across start–finish line.

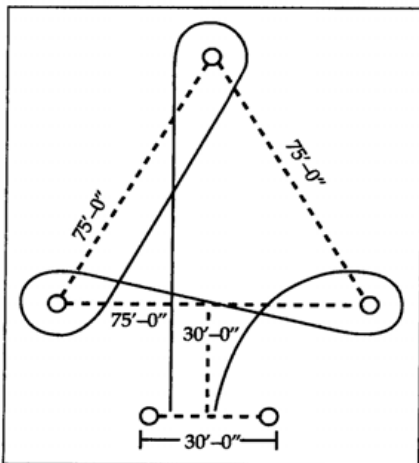

DRIVING POLE BENDING

Course: Six (6) markers placed in a straight line, spaced 25 feet apart with the start–finish line 25 feet in front of the first marker.

Pattern: May be driven in either direction. Driver crosses start–finish line, drives down the right or left side of markers; turns around #6 marker and weaves in and out of the line of markers; turns around #1 marker and weaves in and out of the line of markers again; turns around #6 marker and drives across the start-finish line

TRAIL OBSTACLE DIVISION

The trail obstacle course should be posted prior to class. It is suggested that this class be divided into Adult and Youth classes when there are sufficient entries.

For tack and attire, see equipment chart.

The trail course shall resemble obstacles and occurrences that may occur on the trail. Individual horse and rider shall negotiate an obstacle course consisting of a minimum of six (6) obstacles, three (3) of which are mandatory, as listed below. Final consideration of the Judge shall include quality and smoothness of the performance of the horse and neatness and ability of the rider.

This class will be judged on the performance of the horse over obstacles, with emphasis on manners, response to the rider, and quality of movement. The ideal trail horse shall negotiate the course in a calm and efficient manner by demonstrating sure-footedness; by looking at and working through the obstacle without hesitation and without rushing through the course; and by moving willingly without excessive urging by the rider.

Entry may be either English or Western, but not a combination of both. If the horse and rider use Western tack, the reins must be held with one hand and cannot be changed during the performance (except as noted below). Horses five (5) years old or younger may be exhibited in a snaffle bit or bosal, but the rider must use two hands. Rider's hands shall be free of the horse and saddle.

EXCEPTION – Rein hand may be changed when:

- Working the gate
- Putting on or removing a slicker
- Carrying/Dragging an object from one part of the arena to another

The use of skid boots, splint boots, polo wraps, unweighted bell boots or other approved leg protection device is permitted.

A cavesson is required in English tack and **is not permitted** in Western tack.

Hunt Seat tack and attire are allowed. The horse must be exhibited in a snaffle bit and the rider must use two (2) hands.

Youth riders 11 and under may use both hands on the reins when using western tack.

Whips or bats are prohibited with any tack or attire.

A time limit may be set for the course; however, the time itself will have no bearing on the final placement, except as a limit for course completion. If a horse takes excessive time at an obstacle, the judges are encouraged to advance the horse to the next obstacle.

All individual ground poles and timbers, used to construct the course, shall be free to move and high enough to break the stride of the horse.

MANDATORY OBSTACLES (may pick any three (3) from the following list):

- a) Opening, passing through, and closing a gate (one that does not endanger horse and rider).

The gate may be a stiff or rope gate. The gate latch/rope shall be accessible to rider and approximately five (5) feet above ground level.

- b) Cavaletti (work over at least four (4) ground poles or logs spaced on the ground). Maximum height of twelve (12) inches. Minimum height 3.5 inches. Spacing between logs or poles:
 - i. Walkover: 22" – 26"
 - ii. Elevated walkover: 22"
- c) Ride over wooden bridge (may be plywood laid on the ground to simulate sound and appearance of bridge). Bridge must be a minimum of thirty-six (36) inches wide and no less than six (6) feet in length. Bridge should be sturdy, safe and should be negotiated at a walk only.
- d) Ground tie horse, walking a full circle around horse.
- e) Back through and /or around at least (3) objects, such as barrels, poles or cones. The back through obstacle can be an "L", "V", "U", straight or similarly shaped course. Sides or opening of back through should be a minimum of 30 inches apart.

SUGESSTED OPTIONAL OBSTACLES:

- a) 90, 180 or 360 degree turn inside four (4) poles placed in a box configuration six (6) to eight (8) feet on each side.
- b) Walk or lope over ground poles. Spacing between poles:
 - i Walkover: 22" – 26"
 - ii Elevated walkover: 22"
 - iii Lope over 6' – 8'
- c) Water hazard
- d) Side pass over log(s) or pole(s), in a straight line, zig-zag or "L". The obstacle shall consist of objects which are safe and will not roll or entangle the horse.
- e) Carrying objects
- f) Put on and remove a slicker.
- g) Remove and replace materials from a mailbox.
- h) Tarps, provided that they are secured in a fashion so that they will not move.
- i) One (1) jump, not less than fourteen (1) inches nor more than twenty-four (24) inches high, ridden over.
- j) One (1) jump, not less than fourteen (1) inches nor more than twenty-four (24) inches high, led over.
- k) Ground tie, pick up designated foot or feet.
- l) Serpentine around poles, barrels, etc. Minimum spacing between obstacles should be at least thirty-six (36) inches for the walk or thirty (30) - fifty (50) feet for the lope or canter.
- m) Carry or drag objects that might reasonably be expected to be carried on a trail ride.
- n) Forehand or hind-quarter turn with the horse's front or hind feet inside a lined circle.
- o) Cowboy curtain (a tarp cut into strips or pool noodles safely suspended from a frame that the horse and rider pass through).
- p) Other obstacles that would reasonably be encountered on the trail and can be expected to be safely negotiated by horse and rider.
- q) Live animals, tires, rocking or moving bridges, flames, high jumps or any obstacle that could be deemed unsafe are prohibited in any trail obstacle class.

In designing a course, individual obstacles must be separated by at least 30 feet if the pattern requires a flat walk or a running walk between obstacle locations and 50 feet if it calls for a canter/lope between obstacle locations. There is no minimum distance required between obstacle locations to be

negotiated at the walk. In the design of all obstacles and maneuvers, the length of a horse, from nose to tail, should be considered to be 8 feet. More advanced obstacle courses should call for exhibition of four gaits (trail, flat walk, walk, and canter/lope).

INSPECTION OF THE COURSE

Exhibitors will be allowed to walk and inspect the course (without the horse) prior to the start of the class and may alert show management or the judge, prior to the beginning of the class, if they find any obstacles to be unsafe. No horse may enter the trail course area until the course and the judge are ready.

The judge must also walk the course before the class and shall have the right and duty to assess the safety of the course. The judge may move, remove, or change any obstacle deemed to be unsafe or non-negotiable. If, at any time, an obstacle is deemed to be unsafe by the judge, it shall be repaired or removed from the course. If an obstacle is removed, horses that have completed the course shall have the score for that obstacle removed from their score sheets.

SCORING AND PENALTIES

- a) Scoring will be on the scale of 0 – 100, with 70 denoting an average performance. Each obstacle will receive an obstacle score and may also be subject to penalties listed in paragraph b) below. Each obstacle will be scored on the following basis:

- 1 ½ extremely poor
- 1 very poor
- 1/2 poor
- 0 correct
- +1/2 good
- +1 very good
- +1 ½ excellent

Obstacle scores are to be determined and assessed independently of any penalty points.

- b) Penalty points should be assessed per occurrence as follows:**

½ Point

- Each tick of log, pole, cone or obstacle

1 Point

- Each hit of, or stepping on, log, pole, cone or obstacle
- Break of gait at walk, flat walk, running walk, canter/lope, or on the wrong lead for two strides or less.
- Skipping over or failing to step into required space
- Split pole in lope over
- Incorrect number of strides, if specified

3 Points

- Break of gait at walk, flat walk, running walk, canter/lope or on the wrong lead for more than two (2) strides
- Knocking down an elevated pole, cone, barrel, plant, obstacle or severely disrupting an obstacle

- Stepping outside the confines of, falling or jumping off or out of, an obstacle with one (1) foot

5 Points

- Dropping slicker or object required to be carried on horse
- First or second cumulative refusal, balk or attempting to evade an obstacle, by shying or backing more than two (2) strides away
- Letting go of gate or dropping of rope gate
- Use of either hand to instill fear or praise
- Falling or jumping off of or out of a bridge or a water box with more than one (1) foot once the horse is in or on that obstacle
- Stepping outside of the confines of an obstacle with designated boundaries (i.e., back through, 360 degree box, side pass) with more than one (1) foot once the horse has entered the obstacle
- Blatant disobedience (including kicking out, bucking, rearing or striking)
- Holding saddle with either hand

Failure to negotiate an obstacle (0 score on obstacle)

- Third cumulative refusal, balk, or evading an obstacle by backing – directed by judge to pass on to next obstacle
- Attempted but did not complete obstacle
- Failure to demonstrate correct gait between obstacles as designed

Disqualification (not eligible for any placing in the obstacle class)

- Fall of horse or rider
- Illegal equipment
- Abuse of horse
- Performing the obstacle incorrectly or off-pattern (any order than specified one)
- No attempt to perform an obstacle (off-pattern)
- Equipment failure that prevents completion of pattern
- Entering or exiting an obstacle from the incorrect side or direction (off-pattern)
- Riding outside the designated boundary of the arena or course area (off-pattern)
- More than one (1) finger between the reins, except when changing hands to work an obstacle
- Failure to follow the correct line of travel between obstacles
- In Western tack, use of two (2) hands or changing hands on the reins, except where permitted, as described above (except for junior horses ridden in a bosal or snaffle bit)

If an exhibitor is assigned a score of “0” on one or more obstacles, they are included in the award placings (that is, if there are fewer horses in the class than there placings). An exhibitor assigned a “0” score on one or more obstacles may be awarded a ribbon, but cannot be placed over an exhibitor with no “0” scores. Disqualified exhibitors may not receive any award, no matter the number of entries.

IN-HAND TRAIL

The course will consist of a minimum of six (6) obstacles. It should be designed in a way so as to demonstrate the horse's willingness and ability to please as well as the skill of the exhibitor in cueing the horse for the various obstacles. All obstacles must be safe for both the horse and the exhibitor and the judge has the right to alter the course for safety. Horses are to be shown in a nylon, leather or rope halter, to be correctly fitted, and a nylon, leather or rope lead. Attire for the exhibitor should follow the requirements for showmanship. Edible treats to encourage the horse to perform are not allowed. The class is judged on performance and way of going with emphasis on manners.

Classes may be offered for yearlings or horses two (2) years or older and may be limited by the age of the exhibitor.

OBSTACLE TRAIL SCORE SHEET

Judge----- Date-----

- Maneuver Score +1 ½ Excellent; +1 Very Good; +1/2 Good; 0 Average ; -1/2 Poor; -1 Very Poor; 1 ½ Extremely Poor
 Penalty ½ : Tick on obstacle.
 Penalty 1: Hit or step on; Not stepping in required space; Break gait 2 or less strides; Split pole in loper-over.
 Penalty 3: Disturb obstacle; Wrong gait 2+ strides; Stepping out of obstacle with 1 foot; First & second refusal;
 Penalty 0: Perform obstacle incorrectly; Bypassing obstacle; Third refusal.

Back No	Penalty Maneuver													Penalty Total	Final score
	Penalty														
	Maneuver Score														
	Penalty														
	Maneuver Score														
	Penalty														
	Maneuver Score														
	Penalty														
	Maneuver Score														
	Penalty														
	Maneuver Score														
	Penalty														
	Maneuver Score														
	Penalty														
	Maneuver Score														
	Penalty														
	Maneuver Score														
	Penalty														
	Maneuver Score														
	Penalty														
	Maneuver Score														

Sample Side Pass Obstacles

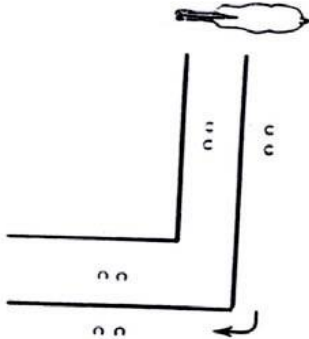
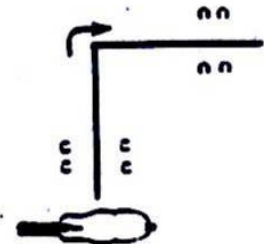
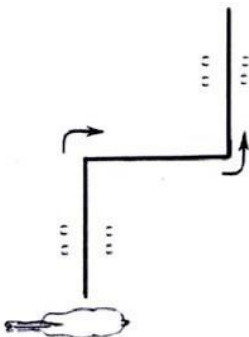
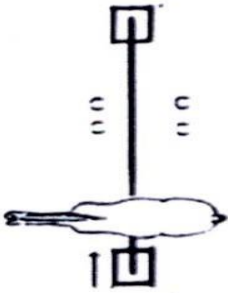

Sample walk-overs (can also be used as lope-overs with increased spacing)

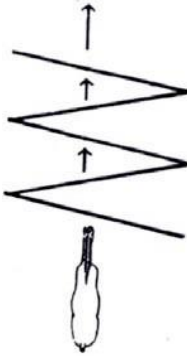
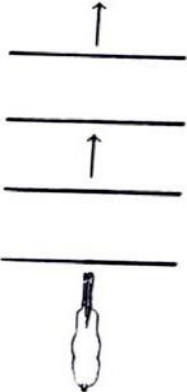

TWH OVER FENCES

Appointments

See equipment chart.

Course

- Course consists of 8 fences (minimum of 2 feet; maximum of 3 feet) and at least 4 different obstacles. An obstacle may be jumped more than once. A fence must be at least 12 feet wide or have wings at least 30" wide that are 12" higher than the fence (pen jumps excluded).
- Course must have at least 1 change of direction with a change of lead.
- A simple fence such as post and rail should be used as the first obstacle on the course.
- Fences should simulate obstacles found in the hunting field, such as natural looking poles and rails, brush, walls, gates and coops. PVC poles used as rails are prohibited. Jumper fences such as bull's eyes and triple bars and spreads of over four feet are prohibited.
- Post and rail fences must have a minimum of 2 rails per fence, excluding ground pole. Space between rails should not be more than 12 inches.
- Jump standards with hole heights at 3 inch intervals are recommended. Standards made of PVC material must be properly secured. The top element of all fences must be securely placed so that a slight brush will not cause a knockdown.
- Wings on obstacles are recommended and if used must be 30 inches wide and 12 inches higher than the top of the fence.
- A ground pole is recommended for all fences. (A pole as long as the jump placed on the ground just below the jump or approximately 18 inches from the base on the approach side.)
- A combination fence such as an "in and out" counts as one fence. Both (a) and (b) should be the same height and 24 to 26 feet is a suggested distance between them for a one stride in and out. For a two stride in and out, 36 feet is suggested and for a three stride in and out, 48 feet is suggested. An in and out fence must never be used at the first jump on a course.
- Rule of thumb for distance between single fences is to use increments of 12 (24, 36, 48, etc.) Fences should be at least 48 feet apart.
- A variation of 3 inches lower than official fence heights may be used if show management or the judge feels circumstances warrant. (footing, weather, etc.)
- Course diagrams must be posted at least 1 hour before the class.
- Exhibitors should have the opportunity to walk the course without their horse to check striding, etc. prior to the class
- A warm-up of two or more fences must be available. Show management may permit one or two fences on the judged course to be used as a warm-up.

Event

When a class is held in a ring, the performance begins as the exhibitor enters the ring and ends when he exits. Circling once before starting the course is customary and

sets the hunter pace which is carried throughout the course. A circle may be made at the finish. Horses should maintain an even hunting pace that covers ground with free-flowing strides. A hunting pace, defined as a long flowing canter with enough speed and impulsion to meet and take each jump with grace and ease, should be maintained throughout the course, including the beginning and the ending circle. Way of going, manners and soundness are to be emphasized. Excessive speed will be penalized.

The ideal hunter will meet each fence squarely, at the proper take off spot for a perfect arc over the obstacle. Its jump will be snappy and athletic with the forearms held at or above a parallel line to the ground. The joints of the front legs are tucked tightly in front of the chest, and the neck and back arched over the fence. Judges will penalize unsafe jumping and bad form, whether the obstacle is touched or untouched. Incorrect leads around the ends of the course or cross-cantering will be penalized. In and outs should be taken in the correct number of strides. In the case of broken equipment, the rider may choose to continue without penalty or stop and correct the situation and be penalized the same as any other loss of forward impulsion. In a refusal at an obstacle with two elements, rider must re-jump both elements.

Faults

- Knock downs (if an obstacle falls after the horse leaves the ring, it is not considered a knockdown) 8 points by horse's front legs; 4 points by any part of the horse behind the stifle. Knockdown of the standard or wing with any part of horse, ride or equipment is 8 faults.
- Extra circle 8 faults each
- Refusal/Run out (if a horse stops in front of an obstacle and immediately jumps the obstacle without backing, it is not considered a refusal) 8 faults each
- When a horse makes 2 faults at one obstacle, only the major fault will be counted, except in the case of a refusal, which will count in addition to the other fault.

Eliminations

- Third cumulative refusal, run-out or extra circle
- Off course
- Bolting from arena
- Deliberately addressing an obstacle
- Fall of horse and/or rider (horse has fallen when shoulder and haunch on the same side touch the ground.
- Jumping out of order or before a jump is reset
- Unsoundness as determined by the judge

TWH Over Fences Course 1

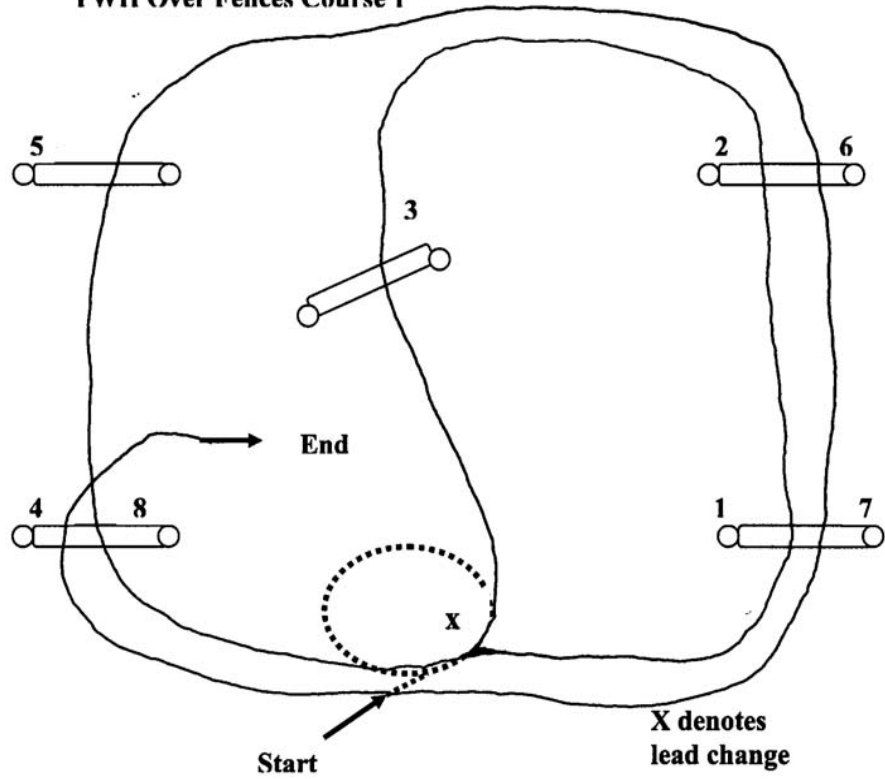

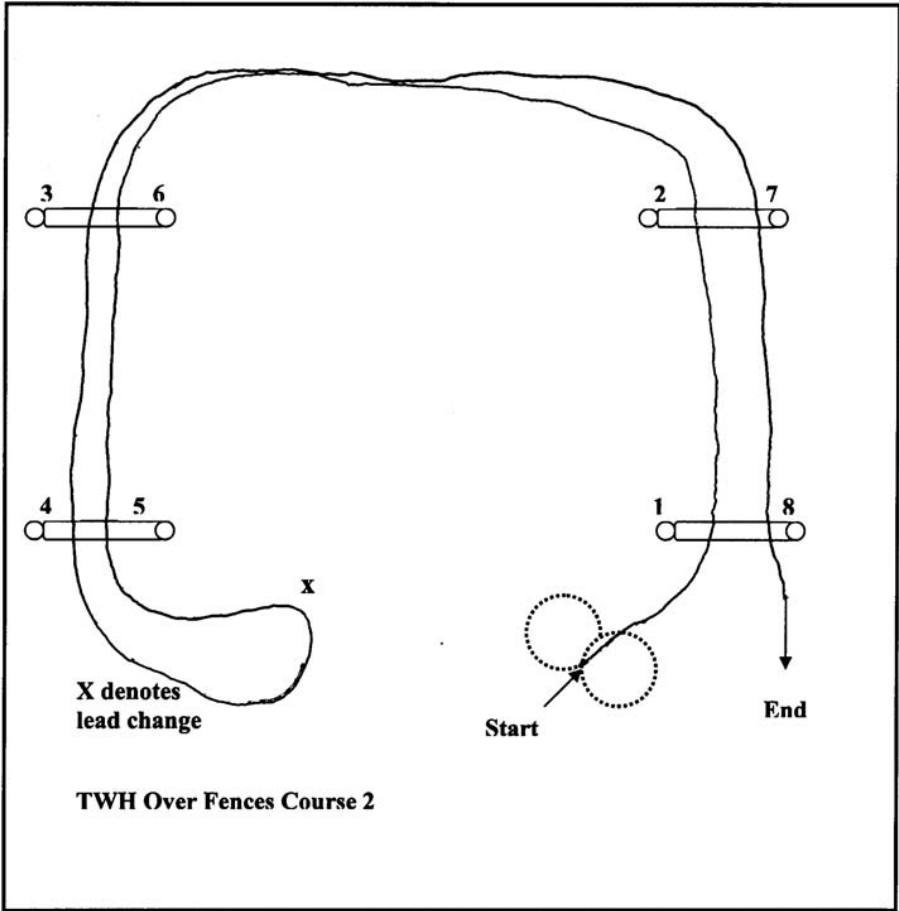

TWH Over Fences Course 3

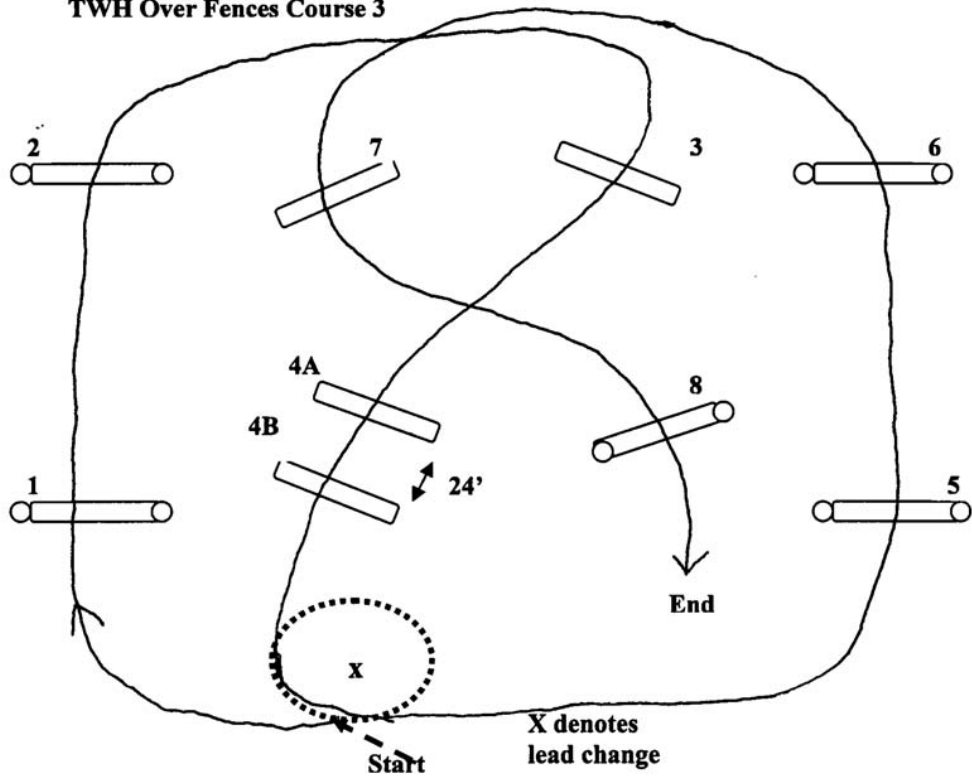

TWH HUNTER HACK

Appointments

See equipment chart

Course

- 2 single fences, 2 feet 3 inches to 3 feet.
- Distance between fences should be in increments of 12 feet but no less than 24 feet.
- A ground pole is recommended for each jump.
- At the discretion of the judge, horses may be asked to hand gallop, pull up, or back and stand quietly after jumping the last fence.

Event

Each entry is first required to jump the course of 2 fences. Faults will be scored as in TWH Over Fences and horses eliminated in the jumping portion of the class shall be eliminated from the rail portion of the class. Following the jumping portion, each eligible horse shall enter the ring to the right and work at the flat walk, running walk and canter both ways of the ring. Horses will be judged on quality of gait, manners, even hunting pace and soundness. Faults in railwork will include being on the wrong lead, excessive speed at any gait, excessive slowness at any gait, breaking gait, over-flexing or nosing out excessively, opening mouth excessively and stumbling.

TWH OVER FENCES, GREEN HUNTER

The same rules apply as in the TWH Over Fences division except the height of jumps and eligibility of horses.

Eligibility

- Horses must be in their first year of showing in over fences classes at Tennessee Walking Horse shows.
- Horses may not compete in both TWH Over Fences Green Hunter and TWH Over Fences classes at the same show.

Course

- Fence height must be 2 feet to 2 feet, 6 inches.

TWH, OPEN JUMPING

Appointments

See equipment chart

Course

- There will be a minimum of 4 obstacles and horse must make a minimum of 8 jumps. Obstacles may be jumped more than once.
- Obstacle height must be a minimum of 2 ft 6 in. and a maximum of 3 ft, 6 in.
- Obstacles may include post and rail, chicken coop, brush jump, stone wall, and triple bar.
- One spread fence of 2 or more elements may be used.
- Obstacles except combinations, should be located at least 48 feet apart., arena size permitting.
- The first obstacle should be no more than minimum height.
- Both a starting line at least 12 feet in front of the first obstacle and a finish line at least 24 feet past the last obstacle must be indicated by markers.

Event

Time begins from the instant the horse's chest reaches the starting line until it reaches the finish line. Time will be stopped while a knocked down jump is being replaced. It will be the rider's responsibility to be ready to continue the course when the signal is given.

Scoring

- Based on knockdowns, disobediences and falls.
- A knockdown is assessed when a horse or rider lowers any part of the obstacle or any element of a spread obstacle, moves any part of the height of the obstacle so it rests on a different support than the one on which is originally rested, knocks down an obstacle, wing or any designated marker. If an obstacle falls after the horse leaves the ring, it is not assessed a knockdown.
- Disobediences include refusals, run-outs, loss of forward movement, and unnecessary circling on the course.
 - A refusal occurs when a horse stops in front of a jump unless the horse immediately jumps the obstacle without taking a backward step. If one backward step is taken, it is a refusal. After a refusal, if the horse is moved toward the jump and does not attempt to jump, it is considered a second refusal. In case of a refusal on an in-and-out jump, the horse must re-jump both elements.
 - A run out occurs when a horse passes or evades an obstacle.
 - Loss of forward movement occurs when a horse fails to maintain forward motion after crossing the starting line, unless it is a refusal, run-out or when due to an obstacle being reset.
 - Unnecessary circling on the course except to retake an obstacle after a refusal or run-out.

WESTERN RIDING

General

In Western riding, the horse exhibits, and is judged on, responsive lead changes at the lope, manners, and a confident disposition. Emphasis is placed on smoothness, even cadence from beginning to the end of the pattern at the walk, flat walk, and lope, and the ability to change leads precisely at marked points between the cones (the gray area between cones). The horse should have a relaxed appearance, including a relaxed head carry and moderate flexing at the poll. The horse should cross the log without breaking gait or radically changing stride.

One of six patterns shall be performed.

On the pattern:

- Markers should be separated by at least 30 feet (9 meters) but not more than 50 feet (15 meters).
- Markers must be a minimum of 15 feet from the fence and with a width of 50 to 80 feet within the pattern, as the arena permits.
- A solid log or pole must be used and be a minimum of 8 feet long and high enough to break the horse's stride.

Tack and Equipment

Western tack and attire are required. Properly worn ASTM/SEI approved headgear is recommended for all exhibitors and shall not be penalized. Silver tack may be used but shall not be given preference over good working equipment. Saddle is to be a western type and must fit both the animal and the rider. Bridle is to be western style. A curb may be either leather or chain, must be western style, and must be at least ½ inch wide and lay flat against the animal's jaw. Split or romal reins must be used. Junior horses five years old and under may be ridden in a snaffle bit or bosal and may use two hands on the reins.

Optional tack: Breast strap, hobbles on saddle when romal is used, skid boots, splint boots, polo wraps, covered stirrups or tapaderos.

Prohibited tack: Mechanical hackamore, draw reins, tie downs, running or other types martingales, cavesson noseband, crops, bats, whips.

Attire: Riders shall wear western style long pants, western style long sleeve, collared shirt, a western hat or a helmet, and western boots.

Optional attire: Chaps, spurs, coats, vest, jacket, gloves.

Scoring

Judges are required to complete scoresheets.

Exhibitors shall be scored on a basis of 0-100 with 70 denoting an average performance. Points will be added or subtracted from the maneuvers as follows:

- 1.5 Extremely poor
- 1 Very poor
- .5 Poor
- 0 Average
- +.5 Good
- + 1 Very good
- + 1.5 Excellent

Maneuver scores are to be determined independently of penalty points.

The following characteristics are considered faults and should be judged accordingly in maneuver scores:

- Opening mouth excessively
- Anticipating signals
- Stumbling

Credits

- Changes of leads, hind and front simultaneously
- Change of lead near the center point of lead change area (gray area).
- Accurate and smooth pattern
- Even tempo throughout
- Easy to guide and control with rein and leg
- Manner and disposition

Penalty points

A contestant shall be penalized each time the following occur:

Five (5) Points

- Wrong lead beyond the next designated change area (failure to change leads including cross cantering). Each failure to change results in an additional five-point penalty.
- Kicking out, biting, bucking, blatant disobedience.
- Holding the saddle with either hand, using the hand to instill fear or praise.

Three (3) Points

- Not performing the specific gait or failing to stop when called for in the pattern within 10 feet of the designated area.
- Simple lead changes
- Additional lead changes anywhere in pattern (except when correcting an extra change or incorrect lead).
- Out of lead, at or before, the marker prior to the designated change area; or out of lead, at or after, the marker after the designated change area.
- In pattern No. 1, failure to start lope within 30 feet (9 meters) after crossing the log.
- Break of gait at the flat walk for more than two strides.
- Break of gait at the lope.

One (1) Point

- Hitting or rolling log.
- Wrong lead more than one stride on either side of the center point between markers.
- Splitting the log (log between two front or two hind feet) at the lope.

One-half (1/2) Point

- Tick or light touch on log.
- Lead changes not synchronous (front to hind or hind to front).

Disqualification – 0 Score

- Illegal equipment
- Willful abuse
- Off course
- Knocking over markers
- Missing log
- Major refusal – Stop and back more than two strides or four steps with front legs
- Major disobedience – rearing, etc.

All horses will be judged immediately upon entering the arena and judging will cease after the last maneuver. Any faults incurred prior to commencing of a pattern will be scored accordingly. Patterns shall be posted a minimum of one hour before the start of the class; however, at the discretion of show management, patterns may be made available prior to the show.

Western Riding patterns and guidelines reproduced with the permission of the NWHHA, TWHBEA, and AQHA.

Location Penalties for Designated Change

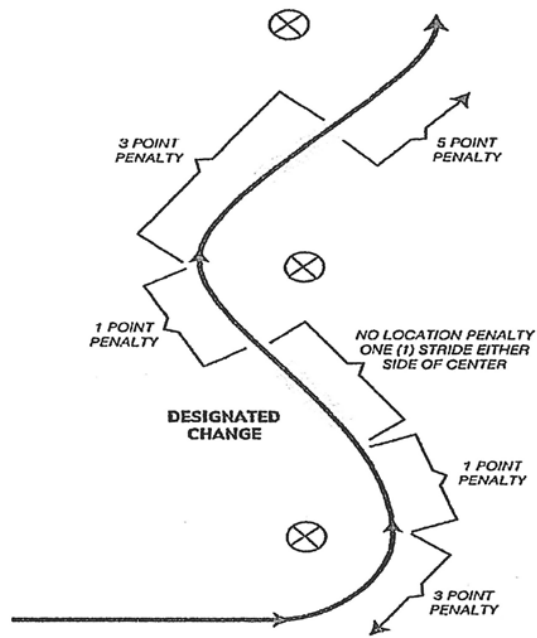

LEAD CHANGING AREA

Location Penalties for Designated Change

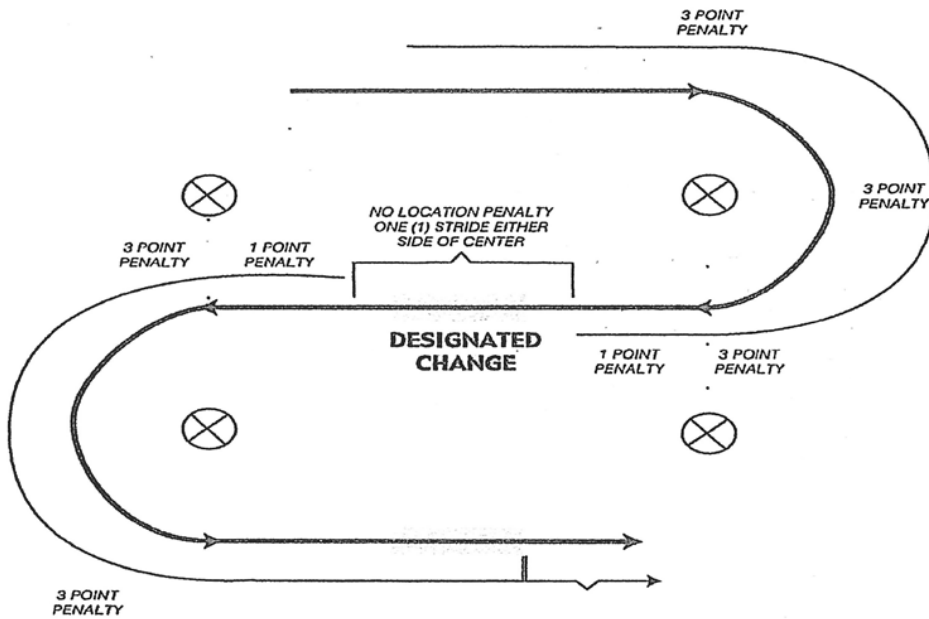

LEAD CHANGING AREA

WESTERN RIDING PATTERN I

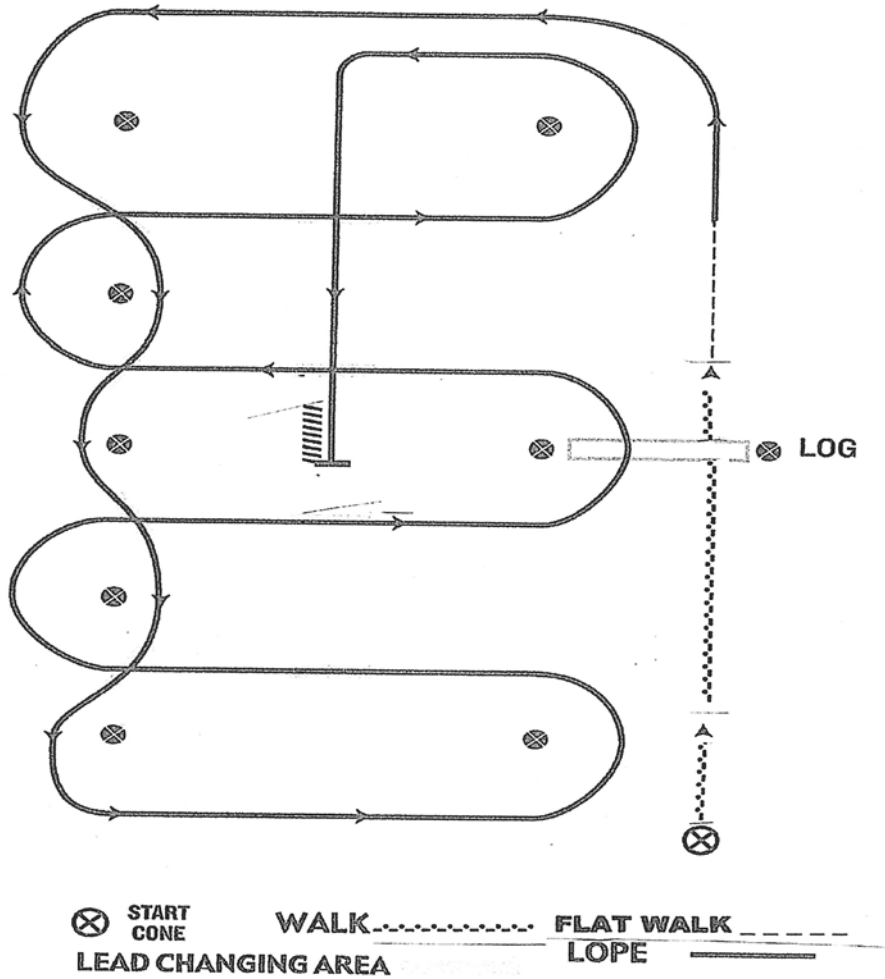

1. Walk across the log and start a flat walk.
2. Before first marker, transition to left lead & lope around end.
3. First line change.
4. Second line change.
5. Third line change.
6. Fourth line change, lope around end of arena.
7. First crossing change.
8. Second crossing change.
9. Lope over log.
10. Third crossing change.
11. Fourth crossing change.
12. Lope up the center, stop & back.

WESTERN RIDING PATTERN 2

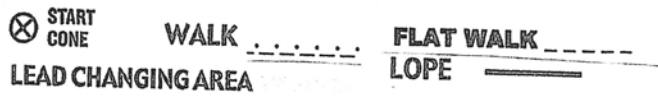
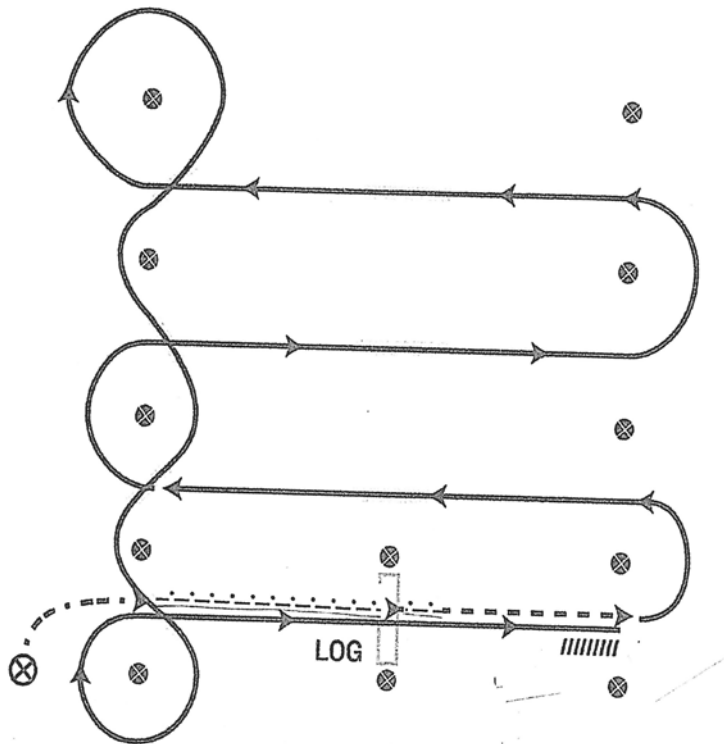

1. Walk over log and start flat walk.
2. Transition to lope on left lead at marker.
3. First crossing change.
4. Second crossing change.
5. Third crossing change.
6. Circle and first line change.
7. Second line change.
8. Third line change.
9. Fourth line change and circle.
10. Lope over log.
11. Lope, stop and back.

WESTERN RIDING PATTERN 3

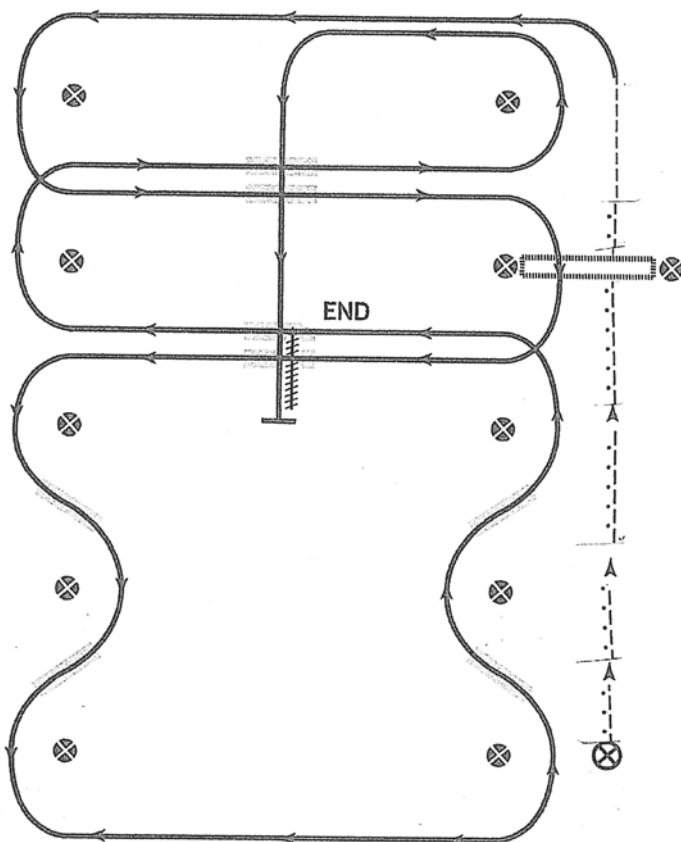

WALK FLAT WALK - - - - - LOPE ———
 LEAD CHANGING AREA [diagonal lines] (X) START CONE

1. Walk over the log and start flat walk.
2. Transition to lope on left lead at first marker.
3. First crossing change.
4. Lope over log.
5. Second crossing change.
6. First line change.
7. Second line change.
8. Third line change.
9. Fourth line change.
10. Third crossing change.
11. Fourth crossing change.
12. Lope up center, stop & back.

WESTERN RIDING PATTERN 4

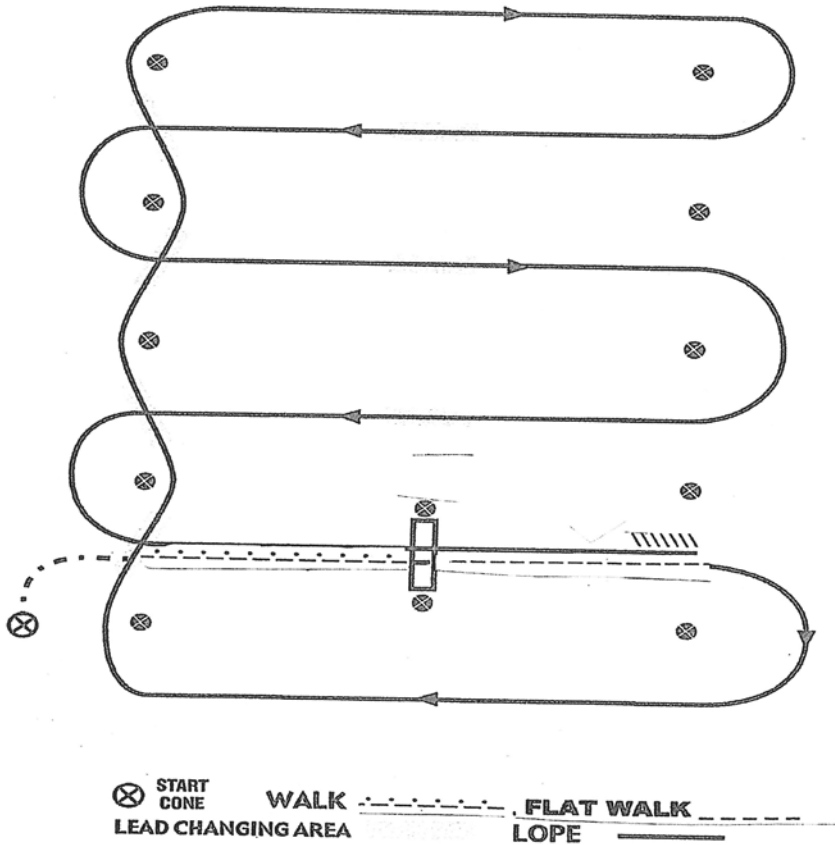

1. Walk over log and start flat walk.
2. Transition to lope on right lead at first marker.
3. First line change.
4. Second line change.
5. Third line change.
6. Fourth line change.
7. First line crossing.
8. Second crossing change.
9. Third crossing change.
10. Lope over log.
11. Lope, stop & back.

WESTERN RIDING PATTERN 5

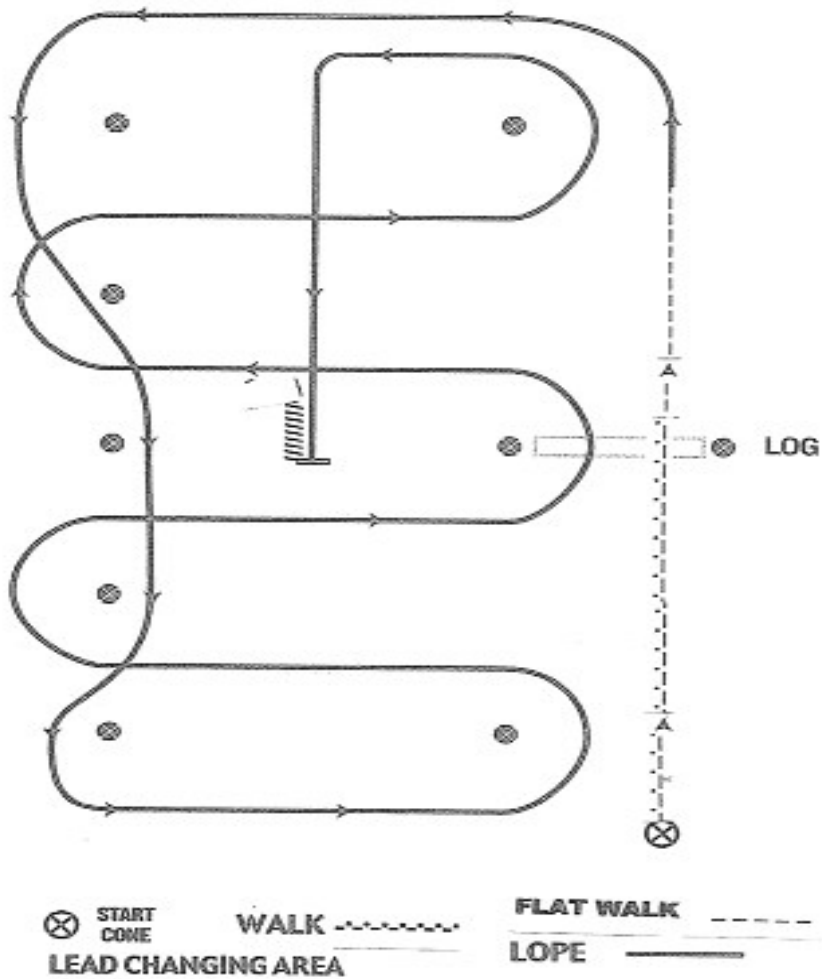

1. Walk over the log and start to flat walk.
2. Before the marker, transition to left lead and lope around end.
3. First line change.
4. Second line change, lope around the end of arena.
5. First crossing change.
6. Second crossing change.
7. Lope over the log.
8. Third crossing change.
9. Fourth crossing change.
10. Lope to center, stop & back.

WESTERN RIDING PATTERN 6

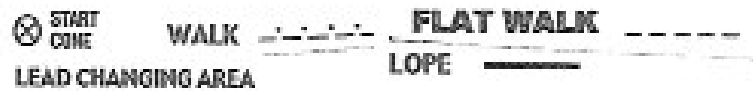
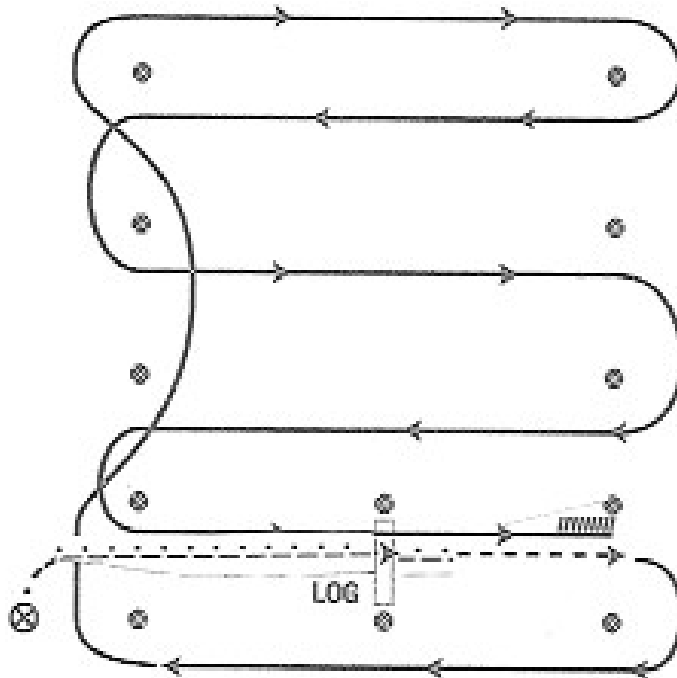

1. Walk over the log and flat walk to the marker.
2. Transition to right lead and lope around end.
3. First line change.
4. Second line change, lope around end of arena.
5. First crossing change.
6. Second crossing change.
7. Third crossing change.
8. Lope over log.
9. Lope, stop and back.

WESTERN RIDING SCORE SHEET

Judge _____ Date _____

Maneuver score +1 ½ Excellent; +1 Very Good; + ½ Good; 0 Average; - ½ Poor; -1 Very Poor; -1 ½ Extremely Poor

Penalty ½ : Tick on log; Non-simultaneous lead change

Penalty 1: Hit/roll log; out of lead one stride either side center point & between markers; splitting log

Penalty 3: Simple change of lead; break of gait at walk and flat walk more than 2 strides; break of gait at lope; not performing specified gait or not stopping where called for in pattern; out of lead at or before the marker prior to the designated change area or out of lead at or after marker after the designated change area; additional lead changes anywhere in pattern.

Penalty 5: Out of lead beyond next designated change area; blatant disobedience.

Penalty Score 0: Illegal equipment; willful abuse; off course; knocking over marker; missing log; major refusal; disobedience.

W/O	Entry No.	Maneuver Description	Walk Log	Trans LL	1L	2L	3L	4L	1X	2X	Log	3X	4X	Stop Back	Penalty Total	FINAL SCORE
			1	2	3	4	5	6	7	8	9	10	11	12		
		Penalty														
		Maneuver Score														
		Penalty														
		Maneuver Score														
		Penalty														
		Maneuver Score														
		Penalty														
		Maneuver Score														
		Penalty														
		Maneuver Score														
		Penalty														
		Maneuver Score														

Working Plantation Horse Competition

The Working Plantation Horse Competition showcases the athletic ability and versatility of the Tennessee Walking Horse as a working ranch or farm horse required to perform a variety of tasks. This horse may be asked to pull, drag and carry objects, open and close gates, travel over rough terrain, cross water, work for long hours, and remain tied or hobbled for extended periods. A well-trained working plantation horse is truly a versatile animal, prized by farmers, ranchers and recreational riders who value the all-around horse.

General Rules:

1. Horses must be registered with TWHBEA.
2. The open division is for a horse shown by an adult or a youth. A youth division may also be offered for exhibitors 17 years and under riding a horse owned by the exhibitor or a member of the exhibitor's immediate family.
3. The competition is comprised of 5 events and each horse/rider combination must compete in each event. Horse/rider combinations will be judged on performance only, except in the conformation class, in which horses will be judged by the breed standard. Each event will be judged separately. Points accumulated in all 5 events will determine the competition winner. While event winners will be recognized, exhibitors should keep in mind that this is an overall competition and not just 5 separate events.
4. The judge will excuse, at his discretion, a rider for unsportsmanlike conduct, vulgar or profane behavior, and cruel treatment of a horse or, any activity that endangers people or animals. An excused rider is not eligible for a refund.
5. The judge will, at his discretion, excuse a rider/horse combination if the horse is deemed to be unsound. An excused horse is not eligible for a refund.
6. Tack and attire should be workmanlike and suitable for work around the farm or ranch, serviceably clean and in good repair. Silver on tack is discouraged but not penalized. No formal riding attire is allowed. Boots are required. Attire should be neat and practical, of a kind that would be worn around the farm or ranch. (Jeans, long sleeved shirt, straw hat or cowboy hat, khaki slacks. No ball caps or t-shirts may be worn in competition. In cold weather, sweaters and/or jackets are acceptable. Workmanlike chaps optional with Western attire.
7. Horse should be well groomed and neat in appearance. Trimming inside ears is discouraged but not penalized. Bridle paths may be trimmed. Tails may be braided if tail length will interfere with the horse's ability to maneuver through class requirements. No braids, no hoof black or polish (Remnants of

polish from other shows are not penalized)

8. Horses may be barefoot or shod with a shoe not to exceed 1” in width.
9. It is recommended that copies of all score cards be given to the rider after the score has been recorded to allow the rider to review the card and use it as a springboard to improving performance in future events. Where time allows, the judge may review each score with the riders in a group setting so that each rider may ask questions and fully understand why the score was given.
10. Event management may choose to affiliate a competition with an HIO for the purpose of inspecting entries for compliance with the HPA. In the event management chooses not to affiliate a competition, management must accept responsibility for ensuring that entries are in compliance with the Horse Protection Act. For that purpose, a steward, veterinarian or other personnel may be provided.

Events

At the beginning of the competition, if space allows, contestants will bring tack to center ring and tack changes will be made there between classes. If space does not allow, contestants may leave arena to make tack changes between classes. If space allows, the judge may choose to have each horse complete the trail course immediately after finishing the working Western pattern. This must be announced at the start of the competition.

1. Conformation (Halter)

Criteria:

- The conformation class will be based on balance, structural correctness, breed and sex characteristics with balance being the most important.
- The horse should have a neat head with well-shaped ears, alert eyes and a tapered muzzle. The expression should be intelligent and kind.
- The neck should be long and graceful, rising from muscular, sloping shoulders.
- The horse should be deep in the girth, well ribbed and the chest should be well proportioned.
- The back should be short and well coupled at the loins.
- The croup should be sloping and the hips well muscled.
- The legs should be flat and cordy, with hoof enough to support the weight of the horse. Hoof length should lend itself to usefulness on the trail or on a variety of terrain.
- Extreme sickle hocks, cow hocks, etc., should be penalized.
- Transmissible weaknesses and/or unsoundness must be penalized. Minor blemishes are not penalized.

Procedure:

- Horses are to be shown in a good working halter (rope, braided, nylon or plain leather).
- Horses will be led both ways of the ring at least 1 circuit of the ring and lined up head to tail for individual inspection. (In a large ring, a portion of the ring may be used)
- The judge shall inspect each horse from both sides, front and rear.
- The judge may ask any entry or entries to move out at either a flat or running walk.

2. Working Plantation Pleasure

Criteria:

- Horses will be ridden in English tack.
- Horses must display the correct four-beat walking gaits with over stride in a manner geared toward covering ground, stamina, and riding for long periods.
- Horses must be well mannered, responsive, and quiet at all gaits.
- A horse should travel with his head held in a normal position, ears alert and moving at a natural speed for the gait requested.
- Smooth transition between gaits will be rewarded and a difference in speed must be readily noticeable between the flat walk and running walk.

- The canter must be relaxed and consistent without visible effort from the rider.
- Horses also will be asked to stop and back.

Flat Walk: A bold, effortless, even, four-beat gait. The horse should drive with the rear legs and appear to pull with the front legs. The fore legs should move straight, breaking at the knees and reaching forward. The horse should be balanced in the degree of knee height to the amount of reach. The hind legs should reach up under the horse's body with minimal hock action, overstepping the print left by the front foot on the same side. Each foot should leave and strike the ground independently. The head should be carried in a natural, relaxed position and must have a pronounced and cadenced head nod which comes out of the shoulders as a result of timing out of the back-end of the horse, and not from simple flexion at the poll.

Running Walk: The running walk has the same footfall, gait quality and general motion as the flat walk, with additional speed and stride. The horse should exhibit a smooth, free and easy, gliding, over striding, four-beat gait, with greater stride and accelerated head motion. The tendency toward trotting, fox trotting, racking or pacing should be penalized. Head motion must be maintained and form is not to be sacrificed for speed. Some horses will click their teeth and/or flop their ears in time with their head nod and should not be penalized for such. Horses with an exaggerated, hesitating way of going and/or a tendency to "point" must be penalized. Head tossing, going sideways, laboring and tail switching are not desirable.

Trail Walk: The trail walk must be on a loose rein. At the trail walk, the rider should be able to take a sandwich out of his/her saddlebag and eat it while the horse quietly moves forward in a relaxed and willing manner.

Canter: The canter is a smooth, controlled and straight three-beat gait. The horse should not be walking behind, but cantering on both ends with a rolling, rocking chair motion. A horse that is on the wrong lead or cross cantering must be penalized. Excessive pulling or pumping the reins at the canter must be penalized.

Procedure:

- Horses enter the ring in a counter-clockwise direction and perform all three gaits both ways of the ring.
- Upon direction of the judge or ring steward, horses will line up and be asked to back individually.

3. Water Glass

Each rider will hold a full glass of water as the horse performs the flat walk and running walk both ways of the ring. In case of a tie, the canter may be called and other maneuvers as devised by the judge may be used. Tack may be either English or Western but not a combination of both.

4. Working Western

Criteria:

- Horses will be ridden in Western tack
- Gaits are flat walk, running walk, trail walk, lope and extended lope.
- Horses must display the correct four-beat walking gaits with over stride in a manner geared toward covering ground, stamina and riding for long periods.
- Horses should travel quietly on a loose rein with heads held in a relaxed position, ears alert and moving at a natural speed for the gait requested. High headedness and heads behind the vertical are not desirable.
- Smooth transition between the gaits will be rewarded and a difference in speed must be readily noticeable between the flat walk and running walk.
- The lope must be relaxed and consistent without visible effort from the rider
- Extended lope should be slightly faster but not a gallop and must remain under control at all times.
- Trail walk must be on a loose rein and horse should be relaxed but alert and responsive to rider's commands.

Procedure:

- Horses work the pattern one at a time, with each horse ready to begin when the previous horse finishes the pattern.
- Reins must be held in one hand and cannot be changed during the class. If a rider uses two hands on the reins of a Western horse at any time, the entry will be eliminated from consideration for top placing's. **The exception is when using a bosal or ring snaffle on a junior horse, the rider may use both hands on the reins. When using both hands, the reins should be crossed with the ends falling on either side of the horse.**
- When using split reins, the reins should come over the hand with the thumb resting on top and the rein ends coming out the bottom of the hand and falling free on the same side as the hand holding the reins. One finger may be placed between the reins.
- When using rommel reins, the reins should enter the bottom of the hand with the excess rein coming out the top of the hand and the thumb resting on top of the reins. A finger between the reins is not allowed with rommel reins. The extension is carried in the free hand, falling either straight or neatly coiled. The hand holding the rommel must be at least 18 inches away from the rein hand. The rommel may not be used forward of the cinch or used to signal or cue the horse in any way.

Working Western Pattern

1. Trail Walk from start cone to cone A.
2. Flat Walk from A to B.
3. Running Walk from B to C.
4. Lope on the right lead from C to D.
5. Extend the lope from D to B.
6. Stop at B, hesitate, turn and flat walk to A.

7. Lope on the left lead from A to E.
8. Trail Walk from E to C.
9. Stop and back approximately one horse length.

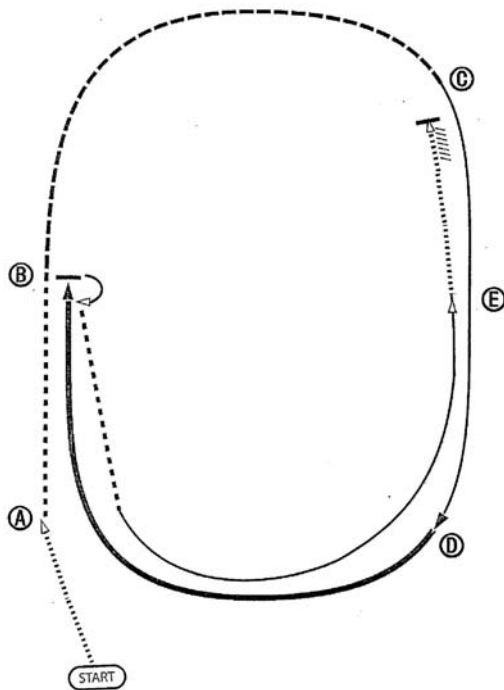

5. Trail Obstacle

Criteria:

- Course includes a minimum of six obstacles designed to show a horse's ability and willingness to perform several tasks that might be asked of him during the course of a normal day's farm or ranch work.
- Highest credit will be given for horses performing the obstacles fluidly, efficiently and willingly.
- A horse will be rewarded with higher credit for performing the gaits correctly (in the case of the canter, on the correct lead) and with an alert attitude.
- Judging for an obstacle shall include the approach, which will begin immediately after departing the starting line or upon departing the preceding obstacle.
- While the course is not judged on time, the horse and rider should make efficient use of time without hesitation or excessive pauses.

Procedure:

- Realistic or natural obstacles are encouraged and the course should be set outside an arena using the natural terrain of the land whenever possible.
- The course may include all three gaits: flat walk, running walk and canter, performed between the six obstacles to be determined when the judge chooses the pattern

- Horses will negotiate the course individually in a timely manner. A reasonable time limit may be set, at the judge's discretion, and contestants may be penalized for exceeding time limit.

Mandatory obstacles

1. Opening, passing through and closing a gate.
2. The rider dismounts, removes the bit completely from the horse's mouth and re-bridles, ground ties and picks up a designated foot or feet
3. Flat walk between 2 rows of cones, poles, logs or similar objects 24 inches apart with real or simulated crop material such as cotton, corn, or other row crops. Tennis balls on top of cones may be used, but plant material is preferred.

Optional obstacles

1. Dragging a small log or branch either in a straight line or around a set pattern.
2. Water hazard – The horse should show willingness to cross a small ditch or shallow pond.
3. Hobble or ground tie (contestant's option) – The horse shall remain in place while the rider dismounts and performs a normal task such as moving a rail, moving a bale of hay, etc.
4. Put on and remove slicker – Rider approaches slicker, removes slicker from holder, puts on slicker and replaces slicker on holder.
5. Remove, carry and replace item – Requires the exhibitor to carry or remove an item that is used everyday on horseback such as mail from a mailbox, sack, rope, etc.
6. Bridge – Horse shows willingness to walk across a bridge or obstacle designed to simulate a bridge.
7. Roping a stationary or simulated steer head. This obstacle is used to show the willingness of the horse to have a rope thrown from its back. The judge will give credit to the horse that stands quietly while the contestant makes the swing and throw at the stationary steer. Shying from the rope will be penalized, but missing the stationary steer will not be penalized.
8. Ride or lead horse over at least four logs laid at odd angles.
9. Move a cow or group of cattle from one area of a pen to another. Agate may also be a part of this task and can substitute for the mandatory gate.
10. Other realistic obstacles to be determined by the event manager and approved by the judge.

A judge has the right and duty to alter the course in any manner or remove any obstacle deemed unsafe. All courses and obstacles are to be constructed with safety in mind so as to eliminate any possible accidents. No jumps, no tires, no obstacles, which are designed purely to attempt to scare the horse. Animals may only be used if they are to be worked by the horse in some manner.

Note: If space allows, the judge may choose to have each horse complete the trail course immediately after finishing the working Western pattern. This must be announced at the start of the competition

ITEMS NEEDED FOR CLASSES:

Baby Bottle Race

- ❖ Baby bottles for each entry

Basic Reining

- ❖ 3 regular cones to mark ends and center of pattern

Catalog Race

- ❖ 1 fifty gallon barrel
- ❖ Catalog or phone book (any large book with numbered pages)
- ❖ 1 or 2 cones to mark start/finish line
- ❖ Electronic timer or 2 stopwatches

Cloverleaf Barrel Race

- ❖ 3 fifty gallon barrels. Plastic barrels are recommended
- ❖ 1 or 2 cones to mark starting line
- ❖ Electronic timer or 2 stopwatches
- ❖ Measuring tape

Dressage

- ❖ Individual test score sheets for each entry, with pencils
- ❖ Dressage arena, usually marked by white fence or chain
- ❖ Clearly visible letters (M,R,B,P,F,A,K,V,E,S,H,C,G,I,X,L,D)
- ❖ Bell or whistle
- ❖ Table & chairs for judge and scribe

Egg & Spoon

- ❖ Eggs (may be boiled or golf balls substituted)
- ❖ Small spoons, plastic or metal

Flag Race

- ❖ 3 fifty gallon barrels. Plastic barrels are recommended
- ❖ 2 cones to mark start and finish line
- ❖ 2 small bucket, at least 2 gallon sized of plastic or rubber filled with corn, wheat, loose sand, or similar material.
- ❖ 1 flag on 18" stick about ½ inch in diameter
- ❖ Electronic timer or 2 stopwatches
- ❖ Measuring tape

Handy Horse

- ❖ Lime or flour
- ❖ 1 fifty gallon barrel
- ❖ 2 cones for start and finish lines
- ❖ Electronic timer or 2 stopwatches
- ❖ Measuring tape

Keyhole Race

- ❖ Lime or flour for outline
- ❖ Measuring tape
- ❖ Electronic timer or 2 stopwatches
- ❖ 1 or 2 cones or other markers for start/finish line

Musical Chairs

- ❖ Chairs, one less than number of teams entered
- ❖ Whistle or CD/Tape player

Musical Sacks

- ❖ Sacks, cones, other markers, one less than number of teams entered
- ❖ 2 cones
- ❖ Whistle or CD/Tape player

Obstacle Driving

- ❖ Electronic timer or 2 stopwatches
- ❖ Measuring tape
- ❖ Other equipment will be dependent on obstacles chosen.
Landscaping timbers, cones, poles, lime for circles, barrels, etc.
- ❖ Set of one red and one white flags or markers for each obstacle.
- ❖ Clearly visible numbers for each obstacle.

Pole Bending

- ❖ Six white poles, usually made of PVC pipe, set into a heavy rubber base. The base cannot be more than 14 inches in diameter and poles should be 6 feet in height
- ❖ 1 or 2 cones to mark starting line
- ❖ Electronic timer or two stopwatches
- ❖ Measuring tape

Quadrangle Barrel Race

- ❖ 4 fifty-gallon barrels Plastic barrels are recommended.
- ❖ 1 cone for center of pattern
- ❖ 1 or 2 cones or other markers for start/finish line.
- ❖ Measuring tape
- ❖ Electronic timer or 2 stopwatches

Ride-A-Buck

- ❖ Dollar bills

Showmanship at Halter

- ❖ 1 or more cones will be needed as markers for showmanship pattern

Stake Race

- ❖ 2 white poles, usually made of PVC pipe, set into a heavy rubber base. The base cannot be more than 14 inches in

diameter and poles should be 6 feet in height

- ❖ 1 or 2 cones to mark starting line
- ❖ Electronic timer or two stopwatches
- ❖ Measuring tape

Straight Line Barrels

- ❖ 5 barrels
- ❖ 2 cones or other markers for start/finish line
- ❖ Measuring tape
- ❖ Electronic timer or 2 stopwatches

Texas T Barrels

- ❖ 5 barrels
- ❖ 2 cones or other markers for start/finish line
- ❖ Measuring tape
- ❖ Electronic timer or 2 stopwatches

TWH Over Fences

- ❖ Minimum of 4 jumps with ground poles; most jumps use at least 2 rails, plus the ground pole. Brush jumps and painted panels can also be used.
- ❖ Warm up of at least 2 jumps must be available
- ❖ Measuring tape

Trail

- ❖ Equipment is dependent on the pattern and/or obstacles used. Logs, a bridge, a gate, small shrubs, cones, a mailbox, barrels are customary equipment for trail classes.
- ❖ Gates should be 50 to 60 inches high and should swing both ways. A rope gate is acceptable.
- ❖ Bridges should be 18 to 24 inches high, at least 36 inches wide, at least 6 feet long. Bridges can be step up, sloping sides and can be set up to teeter totter with a log under the center of the bridge.
- ❖ Logs for walkovers can be landscape timbers, jump rails, or railroad ties. Logs should be placed 15-24 inches for walkovers and, if elevated, must be a minimum of 22 inches apart.
- ❖ A back through can be made of poles or straw bales. The back through must be a minimum of 28 inches wide and cannot be elevated more than 24 inches.
- ❖ A pole for a side pass can be elevated no more than 12 inches.
- ❖ Poles set up as a “box” for a 360 degree turn should be placed 6-8 feet wide.

Water Glass

- ❖ Cups marked with exhibitors' back numbers
- ❖ Water to fill cups

- ❖ A ruler or set of kitchen scales

Western Riding

- ❖ 8 to 10 cones, depending on pattern used
- ❖ 1 log

